

Third rail

Electrification

Adding Value

Market-leading third rail solution providing a wide range of benefits for passenger safety, track, and rolling stock.



Pandrol is a world leader in rail infrastructure for metro applications. With Constellium Group, our combined expertise creates an exciting joint venture: 'Railtech Alu-Singen (RAS)'. RAS technology sees the aluminium and stainless steel conductor rail made with coextrusion process, creating a long lasting and reliable material that's a game-changer in the development and manufacture of complete composite conductor rail systems solutions.

This revolutionary method delivers the highest levels of reliability and safety on the market, with no delamination (separation of the combined metals) and – because it works down to 0 mm – no need to monitor the thickness of the stainless steel.

Pandrol's third rail solutions are specifically designed with consideration of rolling stock, track works, power supply and civil works interfaces in mind, which means they can be adapted to work on all track types. The Pandrol team has extensive across-the-board experience and offers a comprehensive RAS support service, from product engineering and design, through to proof of concept testing, system design, installation supervision and bespoke training.

→ TECHNICAL FEATURES

Coextrusion technology

Coextruded rail delivers industry-leading levels of reliability and safety, with an increased lifetime. The highly specialised coextrusion process which ensures there's a strong, reliable, corrosion-free bond between the aluminium body and the stainless steel strip. The risk of delamination of the stainless steel strip – even if it has been partially worn down – is completely eliminated when the RAS system is used.

Insulation protection

Our insulating covers provide the highest possible levels of safety and protection for people working near the track.

Global track expert

We propose integrated track solutions with our Division Fastening Systems. With our track expertise, we are able to anticipate and solve issues proposing the best solution for the product and its interface with its environment.

Specialised tooling

We have developed a full range of dedicated tools to ensure the third rail installation is as smooth and as cost-effective as possible. Added to this, all of our processes and materials are underpinned by the philosophy that all installation and maintenance activities need to be fast, reliable and safe.

Unmatched engineering and field expertise

With over 2000 km of our third rail installed across the globe, we're truly world leaders in the field. Our expert teams have the knowledge, reactivity and flexibility to support you at every stage of your journey – and our unrivalled field experience means we're always prepared for whatever surprises are thrown up along the way.

→ ADVANTAGES /

- Working with Pandrol means working with world leaders in third rail technology.
- 'Railtech Alu-Singen (RAS)' system is quick, cost-effective and simple to install and maintain – as well as offering the best lifespan on the market.
- The system is configured so that the stainless-steel strip can be fully worn down to 0 mm without any need to check that it's still working, generating significant cost reductions on maintenance.
- The system is capable of offering top, lateral and under-running solutions.
- All Pandrol products have been specifically designed with the wider railway environment in mind. Every product and process is tested to meet the highest standards of safety, reliability and lifetime value.
- Full training, technical service and support can be provided by our internationally-renowned expert team throughout the installation and commissioning phases.

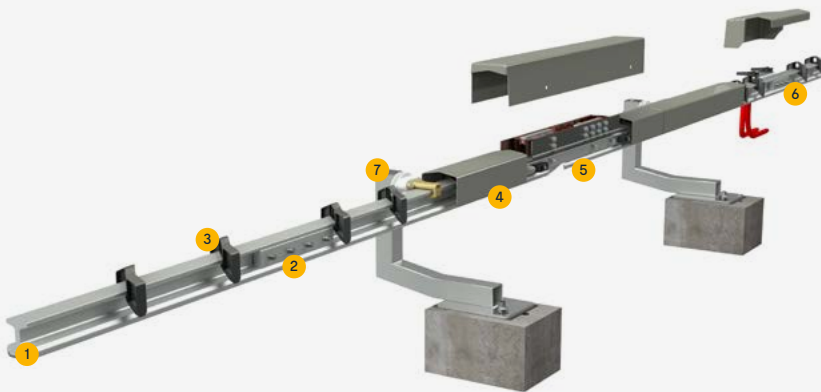

→ COMPONENTS /

1. Conductor rail
2. Splice assembly
3. Cover fastener
4. Cover
5. Expansion joint
6. Power Feed block
7. Insulated bracket assembly

→ SOLUTIONS /



Under running solution



Top running solution



Lateral running solution

→ LEARN MORE



www.pandrol.com