

PANDROL VIPA Installation on the Podpeč Bridge between Prešnica and Koper in Slovenia. Slovenian Railways needed to reduce noise emissions from the bridge to improve the environment for local residents.

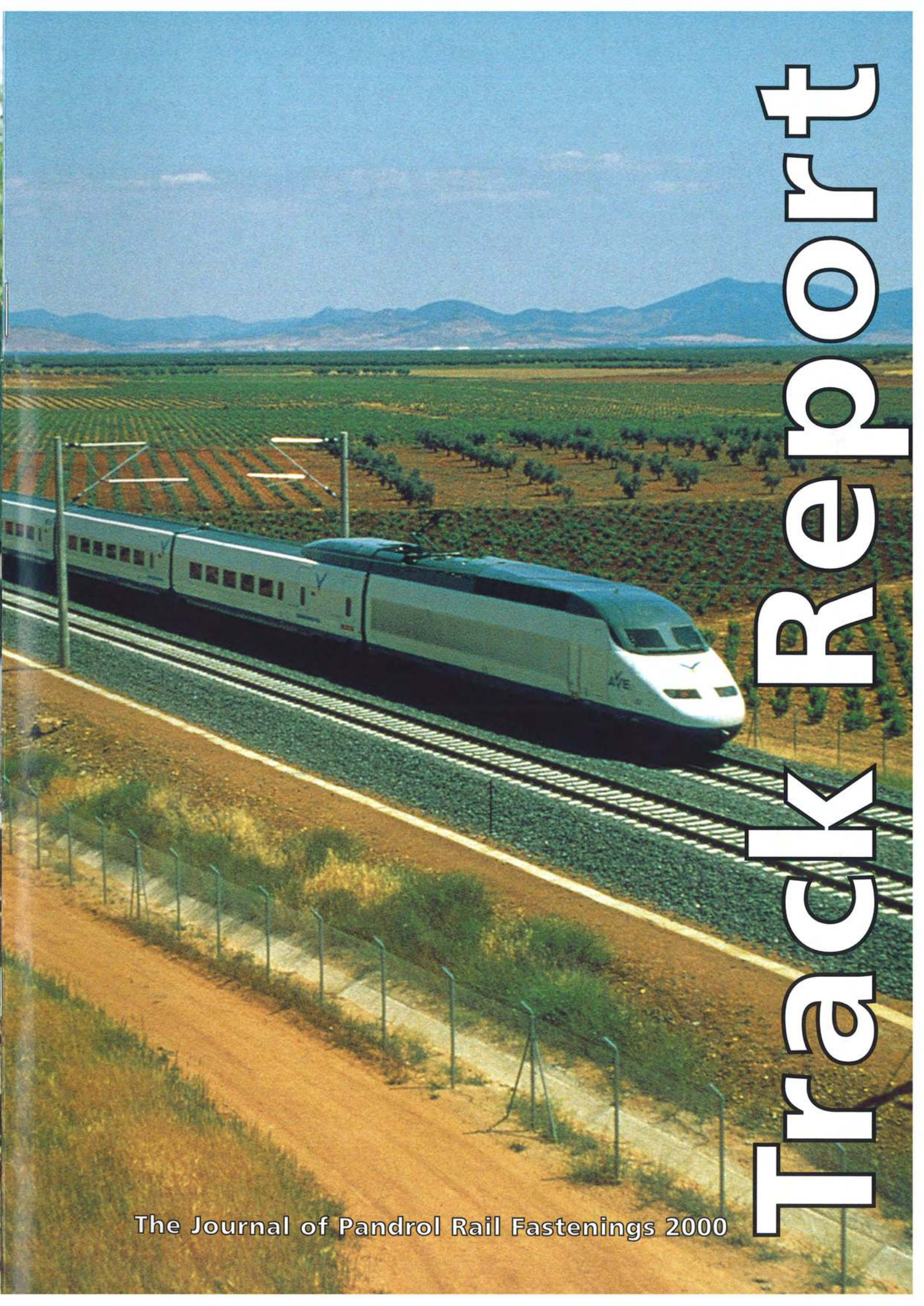

# Track Report

## TRACK SUPPORT SYSTEMS

Alignment and Trackwork on Singapore's North-East Line.....pages 3,4 & 5  
by Tim Wood, Railway Planning and Engineering Consultant/Adviser, Singapore.

VANGUARD on London Underground.....pages 6,7,8 & 9  
by Keith Sunley, C. Eng, M. I. Mech. E., M.I.C.E., Engineering Consultant.

Vibration Isolation on Steel Bridge Structures - Solution for Manila's MRT Line 3.....pages 10,11 & 12  
by Mr Mario C. Miranda, Project Director - EDSA MRT Project Management Office,  
Department of Transportation and Communication, Republic of Philippines.

## PANDROL FASTCLIP

G44 Dual Rail Assembly for Railtrack.....pages 13 & 14  
by David Bateman, Principal Asset Manager (Track), Railtrack Asset Management.

Construction of the West Basin Intermodal Container Transfer Facility  
for the Port of Los Angeles.....pages 15 & 16  
by Stephen C. Kapantais, Project Manager, Modern Continental.

Installation of PANDROL FASTCLIP Gauge Convertible Concrete Sleepers  
for TransAdelaide, Australia.....pages 17,18 & 19  
by Terry Brady, Maintenance Manager Rail, John Holland Pty Ltd.  
and Robert Schweiger, Projects & Administration Manager Track and Structures, TransAdelaide.

PANDROL FASTCLIP on Steel Sleepers in the UK.....pages 20 & 21

New Patented Systems for Locking Shoulders into Sleeper Moulds.....page 22  
by Franco De Cicco, Managing Director, S.I.C.I.

## PROJECTS

The Øresund Link Railway.....pages 23,24 & 25  
by Konrad Hove, System Manager, Railway Øresundsbro Konsortiet.

## NEW PRODUCTS

Development of the Lock-In Pad.....page 26

Front Cover: AVE High Speed Trains are now running at 300kph on tracks with PANDROL FASTCLIP assemblies on the Madrid-Seville Line in Spain. Photograph courtesy and property of the RENFE Photographic Archives.

Track Report is published by Pandrol Rail Fastenings Ltd., 63 Station Road, Addlestone, Surrey KT15 2AR England. Telephone: +44 1932 834500. Telefax: +44 1932 850858. E-mail: info@pandrol.com. Website: http://www.pandrol.com

PANDROL, PANDROL FASTCLIP, PANDROL 'e' Clip, PANDROL VIPA and PANDROL VANGUARD are registered trademarks of Pandrol Limited.

Pandrol Rail Fastenings gratefully acknowledge the co-operation of all those contributing to the production of this journal and who have given permission for the use of photographs.

The technical information given in 'Track Report' was correct at the time of printing, but the company undertakes a continuing programme of research and development, and improvements may have since been introduced.

 PANDROL®

# Contents

## TRACK SUPPORT SYSTEMS

### Alignment and Trackwork on Singapore's North-East Line

by Tim Wood, Railway Planning and Engineering Consultant/Adviser, Singapore.

When the Singapore Land Transport Authority (LTA) decided to build the North East Line it introduced some novel engineering ideas, but also wished to retain many of the successful features of the original MRT system. Pandrol developed a 'double FASTCLIP' version of the VIPA assembly ('VIPA-DFC') to give the same low stiffness as the old MRT system (around 20kN/mm), whilst keeping dynamic gauge widening in sharp curves within tightly prescribed limits. This would ensure that environmental vibration levels were no worse on the new line. The system was installed on a curve near Orchard station in 1998 for evaluation, and was then selected for the North East Line, and for the extension of the existing MRT line to the international airport at Changi.

This article describes a number of aspects of the NEL design, including the adoption of the VIPA-DFC track support assembly.

In many respects, the North-East Line (NEL) will be closely similar to existing MRT lines in Singapore. Trains of comparable dimensions and weights will run at comparable speeds, thus imposing comparable dynamic loadings on the track.

The existing track continues to perform perfectly well after over ten years in service and there is no reason to doubt that it will do so indefinitely.

At first sight, it would therefore seem sensible to replicate the existing MRT track forms in the NEL. But this is not being done - why not?

There are several reasons. The NEL has distinguishing characteristics which suggest that replicating the existing MRT designs would not necessarily be the most appropriate technical solution. Moreover, technology has not been standing still: ten years of product development have thrown up interesting new possibilities. And because the NEL will be entirely self-contained, operated and maintained quite independently of the existing MRT lines in Singapore, there are no constraints dictating that the track form(s) for the NEL should be compatible with those of the existing system.

#### DISTINGUISHING FEATURES OF THE NEL

The NEL will be a fully-automatic railway with no operational need to have traincrew on board. Hence there will not necessarily be anyone to report unusual noises or other unusual experiences which may betray the sudden

emergence of a track fault during traffic hours.

Moreover, crewless trains imply that, if there were to be any switch throw detection failure or any other hardware malfunction during traffic hours, any need to admit maintenance personnel into the tunnel will have to be subject to rigorous safety procedures which might seriously prolong the restoration of normal services.

In other words, a capability to detect faults before they threaten service interruptions will be of paramount importance in achieving acceptable standards of service performance.

The NEL will be entirely underground and will therefore everywhere comprise concrete slab track. This is not the forum in which to rehearse the well-known economic life-cycle cost arguments about why this should be so, but there are two issues which deserve serious attention here - the long-foreseen one of the need to attenuate noise and vibration propagation in particularly sensitive areas; and the subtler, more recently-comprehended one, to do with the renewal of worn defective rails.

#### Alignment Setting-Out Line

In conventional track, that is (until recent years) in ballasted track, the Engineer has had no



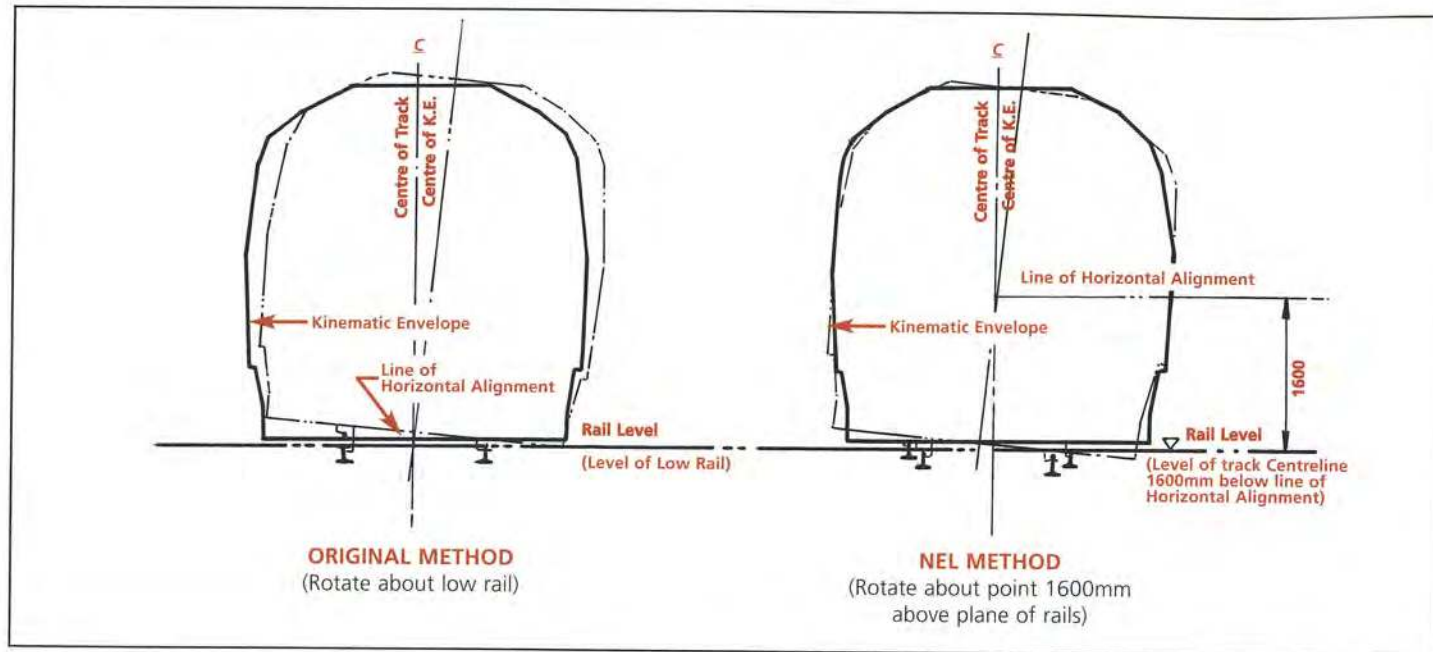

Figure 1 - Definition of horizontal alignment and point of rotation for applying cant.

practical choice but to set out the alignment at rail level and to apply cant by lifting the high rail relative to the low rail.

Historically, in tunnels containing curves, the tunnel cross section would typically (but uneconomically) be enlarged to accommodate the full range of horizontal and vertical shifts in the position of the kinematic envelope relative to the design alignment of the track. In more recent years the tunnel cross section would be shifted laterally and / or vertically relative to the design alignment of the track to suit the displaced kinematic envelope.

Experience teaches that the latter (economically preferable) technique provides fertile ground for unwitting mistakes.

On the NEL there is a multiplicity of Tunnel Boring Machines (TBM's), many of which encounter curved track from the day of their launch. The device of preserving constant, rather than variable, horizontal and variable offsets between the design alignment of the track and the design alignment of the tunnelling contractors at the beginnings of their learning curves.

A secondary advantage is that the decoupling of the cant from the tunnel alignment postpones the date by which cant design must be completed. This avoids the risk of premature definition of cant based on preliminary speed/distance profile predictions.

The geometry of the alignment at rail level must depart from conventional expectations, but once the track is embedded in concrete, there are no adverse implications for future maintenance (see Figure 1).

**Speed Restrictions**

In most railway administrations in the world, permissible speeds through curves are governed by comfort criteria. Where there is a driver, even empty trains are subject to the same rules. On the NEL there will usually be no-one at all on board trains from which passengers have disembarked. This means that permissible speeds through curved track layouts may be raised, provided that a sufficient factor of safety against derailment is preserved.

On the NEL, recognition of this benefit has saved considerable sums of money in the provision of reversing facilities at the World Trade Centre and on the test track in the Depot.

**TRACKWORK Trackbed Design**

The shape of a prestressed concrete sleeper is typically shallower at its centre than at the railseat. The transformation of its cross-section must be gradual to avoid unwanted stress concentrations. A pretensioned, prestressed sleeper cannot be demoulded until the concrete achieves sufficient compressive strength to withstand the prestressing force.

In contrast, a reinforced sleeper can be of whatever shape is wanted. Its sides at least can be demoulded in time to create an exposed-aggregate finish by water-jetting, such that when it is embedded in in-situ concrete it is likelier to exhibit a lesser tendency to separate from its surround. The railseat can be elevated on a plinth, which between railseats creates a sufficient gap between the rail foot and the trackbed concrete to allow standard trackwork jacks and emergency clamps to be used.

**Fastening System**

The fastening system is required to be sufficiently resilient to attenuate significantly noise and vibration by being able to deflect vertically by a maximum of 3.5mm. Hitherto, such deflections have been beyond the reach of conventional spring rail clips alone.

On the NEL, advantage has been taken of the enhanced fatigue resistance of PANDROL FASTCLIP, the latest generation of proprietary rail clips designed by Pandrol to provide the same resilience in an assembly which contains no threaded components. This will at last bring to slab track a resilient fastening which introduces the same inspection and maintenance benefits as have long been available in fastenings for ballasted track (see Figures 2a and 2b).

One recurrent maintenance problem with slab track is matching up the levels of the running surfaces when a worn rail comes to be replaced with a new one. On the NEL, this eventuality is being addressed by including shims under the rail in the original configuration. Shims will be removed from assemblies when a rail has to be replaced, rather than running out the difference in height by creating ramps at each end of the new rail (see Figure 3).

**Stray Current Corrosion Control**

A continuous conductor, running along the tunnel wall is the key component in an improved system for detecting and controlling stray currents. Collection mats in the trackbed concrete will be installed in discrete lengths of 100m. These can be individually tested and if

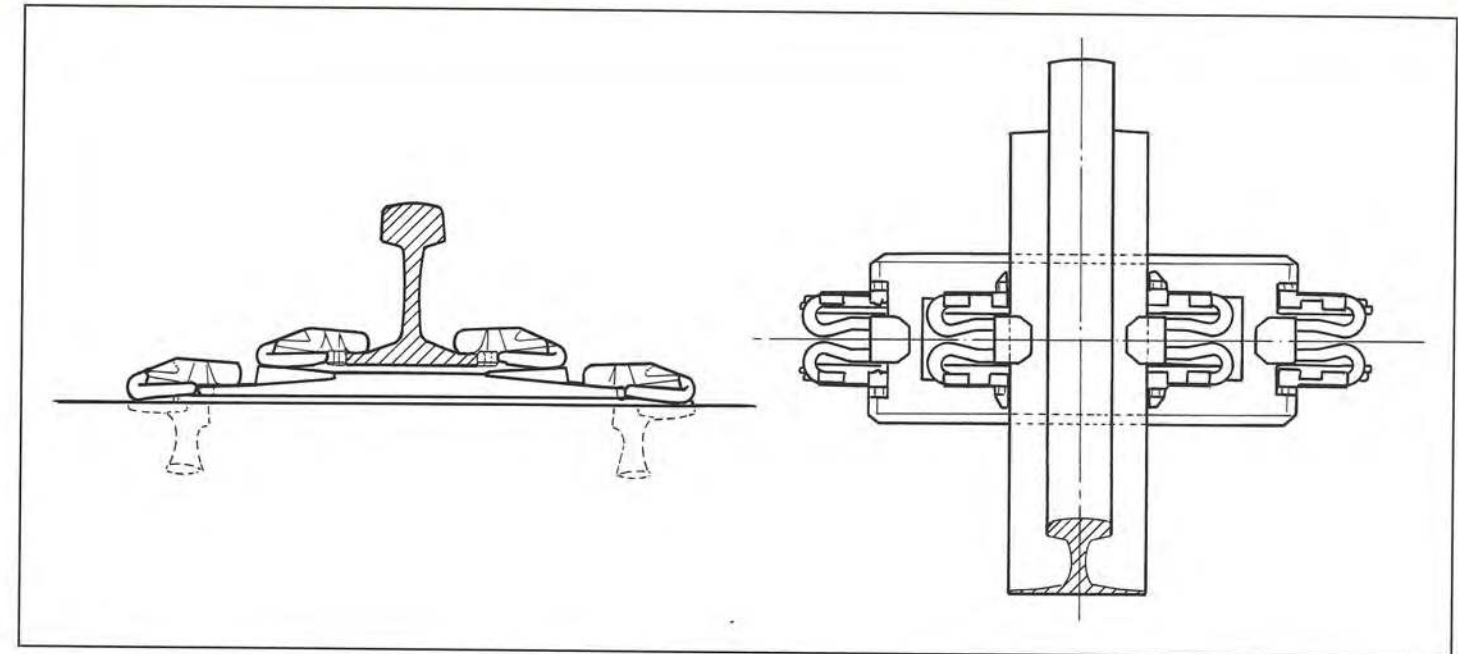

Figure 2a - Double Resilient Slab Track Concept.

necessary individually connected into a stray current drainage circuit.

**Turnout Monitoring System**

Investment is being made in remote sensors at all switches whose unheralded failure would risk disrupting services. By monitoring in particular the force needed to throw the switch and the current drawn by the point motor, worsening conditions can be corrected before they develop into an actual failure.

**Other**

Investment is also being made in a wheel impact load detection system. This is an important element in the strategy to combat noise and vibration nuisance: the acoustic energy generated by out-of-round wheels is several times higher than that generated by wheelsets in good condition. Similarly, a high capacity rail grinding machine will be procured, dedicated to the NEL, to combat rail roughness by frequent light grinding.

**CONCLUSIONS**

The design of the alignment and trackwork for the NEL contains no single dramatic innovations; rather it represents a gradual evolution from preceding practice in a number of individually minor respects. In other words, it remains philosophically conservative without depending on slavish adherence to proven precedent. Perhaps it will become the new starting-point for others to improve on in the future. ■



Figure 2b - Height Adjustable Assembly as installed on the NEL.

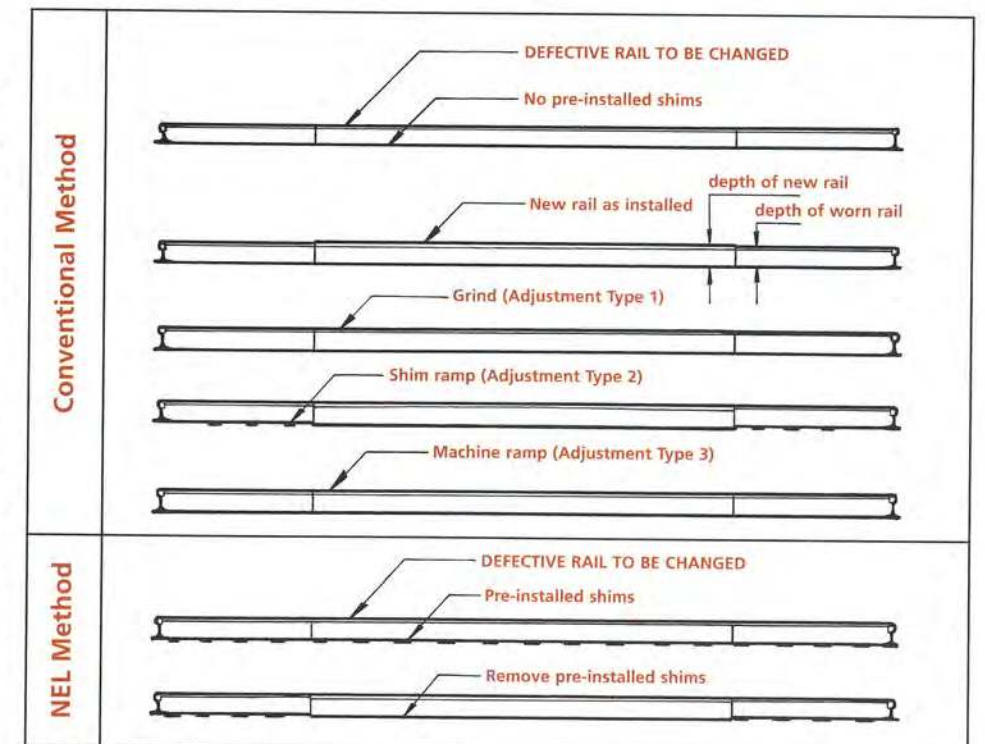

Figure 3 - Replacing a defective rail - techniques for matching heights of running tables.

# PANDROL VANGUARD on London Underground

by Keith Sunley, C. Eng, M. I. Mech. E., M.I.C.E., Engineering Consultant.

It generally comes as a surprise to learn that most of the London Underground is not underground. The total network adds up to 875 km of running lines, and only about 300 km are in deep-bored tube tunnels. However, this still represents a significant length of track. The first deep-bored tube tunnel was built in 1890 and now forms part of the Northern Line. The diameter of the older tunnels was 3.56m, later tunnels such as the Victoria Line were 3.71m and the latest tunnels on the Jubilee Line extension are 4.35m diameter. By most standards these tunnels are old, small and intensively used in a densely populated urban area. It should not be surprising therefore that London Underground receives complaints about noise and vibration from neighbours.

There are ways of reducing noise and vibration caused by the interaction of trains and track - such as resilient base plates to support the rails or floating slab track, where the whole track is resiliently supported, but none of these are suitable for London Underground's small diameter tube tunnels. Resilient base plates tend to be too thick, which would require the rail level to be raised and there is not enough clearance between the trains and the tunnel to allow this. There is also insufficient volume beneath the track to float a concrete track slab with enough mass to be effective.

The PANDROL VANGUARD fastening system was developed to reduce significantly noise and vibration from underground railways within the constraints of an intensively used small tunnel.

## DEVELOPMENT OF THE PANDROL VANGUARD FASTENING.

This paper describes the first trial of the PANDROL VANGUARD system on the London Underground. The design developed for this trial was incorporated in a pre-stressed concrete sleeper and used to renew existing track, but the same concept could be used to design a base plate for timber sleepers or a concrete slab and used for renewal or new construction.

The PANDROL VANGUARD fastening suspends the rail from the web and fishing



A London Underground Victoria Line train.

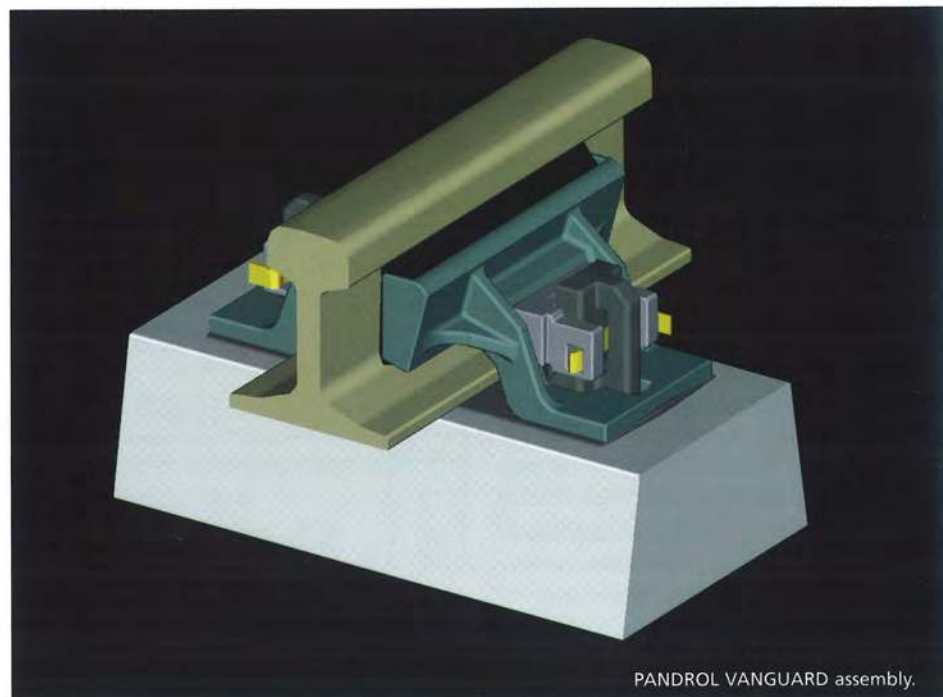

PANDROL VANGUARD assembly.

surface with resilient blocks. The resilient blocks are held in cast iron side plates that transfer the vertical load down to the sleeper. The resilient blocks are compressed during installation, and serrated wedges between the side plates and the shoulders cast into the sleeper maintain this compression and transfer lateral loads to the sleepers. Spring clips are installed between the

wedges and the shoulders. The rail is suspended above the track base, rather than supported on resilient elements beneath it. Because of its novel design, the system can achieve a lower stiffness than a conventional resilient baseplate, but in a shallower assembly. For the first trial, a vertical deflection of 3mm under service traffic was specified.



Staff being trained in the use of the installation equipment.

Installation tools for the trial were developed as well as the fastenings, and staff were trained in their safe use. A sleeper lifting beam was produced to hold the sleeper at the correct lateral and vertical position with respect to the rail while the hydraulic clamping tool was used to install the PANDROL VANGUARD components.

Before PANDROL VANGUARD could be installed on service track, it had to be subjected to exhaustive testing. The durability test involved applying an inclined dynamic load in a laboratory test rig to simulate the maximum lateral and vertical forces experienced in service. After 4.6 million cycles, the static and dynamic stiffnesses of the assembly were re-measured and the components were examined for wear. Other tests were performed to establish the longitudinal, electrical, chemical and fire resistance, smoke and toxic fume emission and compatibility with the signalling system. In all cases the results were satisfactory.

The design that was chosen for trial installation provides the following benefits.

- It can be accommodated within the existing rail height.
- In the trial it uses a tried and tested pre-stressed concrete sleeper, but it could be configured as a base plate for attachment to timber sleepers, a concrete pavement or to blocks.
- The design vertical deflection of 3mm under traffic will achieve good noise and vibration attenuation.
- Changing the characteristics of the rubber blocks could vary the vertical deflection and therefore the noise and vibration attenuation.
- The higher vertical deflection is not associated with significant lateral deflection, therefore the rails are held accurately to gauge under lateral loads.
- When a rail is supported resiliently its greater movement tends to increase the radiated noise i.e. trackside and in-car. Supporting the rail by resilient blocks over 250mm of the web and fishing surface will, to some extent, overcome this.
- Graded vertical adjustability enables new and worn rail heights to be matched when re-railing.
- By changing the side plates and resilient rubber blocks, and without disturbing the shoulders cast into the sleepers, a change of rail section can be accommodated.

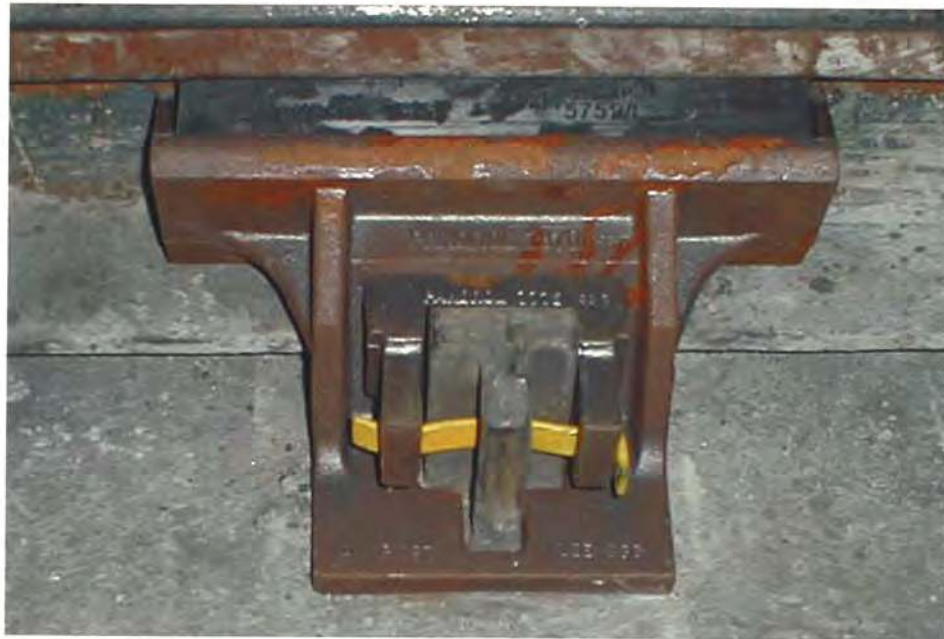

PANDROL VANGUARD installed in track.

**PANDROL VANGUARD TRIAL UNDER SERVICE TRAFFIC.**

The site for the trial is on the Victoria Line, southbound, between Oxford Circus and Green Park in London's West End. The site is 120m long and was chosen because it incorporates curved, transition and straight track and carries 25 MGT per annum.

The existing track at the trial site was flat bottom rail BS113A supported by base plates on timber sleepers at a pitch of 0.914m. The ends of the sleepers were cast into concrete and bridged a trough filled with shingle. The positive conductor rail was supported from the concrete outside the running rails and the negative conductor rail from the centre of the timber sleepers.

The site was re-railed and re-aligned before the installation of PANDROL VANGUARD.

The installation procedure involved breaking out concrete between the timber sleepers, suspending the concrete sleepers from the rails by PANDROL VANGUARD fastenings in the space created and concreting the sleepers in. When all the concrete sleepers had been installed the clips, pads and insulators were removed from the base plates on the timber sleepers. At this stage the rail was supported by the PANDROL VANGUARD fastenings only.

The entire installation was achieved in Engineering Hours between 01.00 and 05.00 and was completed in March 2000.

After the installation of the trial site was completed it was inspected on a weekly basis for the first month and then on a monthly basis and this will continue for the remainder of the first year. The results of these inspections have shown that PANDROL VANGUARD is a successful track fastening.

**NOISE AND VIBRATION PERFORMANCE.**

Noise and vibration measurements were recorded after the existing track at the trial site had been re-railed and re-aligned. This will represent the performance of London

Underground tube track in good condition. The measurements were repeated after the PANDROL VANGUARD fastenings had been installed in order to obtain a direct measure of the benefits achieved.

Instruments were installed in the tunnel half way along the trial site to measure lateral and vertical rail deflection, rail acceleration, tunnel invert acceleration and lateral and vertical tunnel wall acceleration. An accelerometer was also placed in Mill Street above the tunnels.

The rail deflections and tunnel vibrations were measured during the morning peak period when the trains are the heaviest. The measurements showed that the average rail deflection was 3.5 mm vertically and 0.4 mm laterally, which compares favourably with the design values. The tunnel vibrations were measured at several different positions, but the graph shown for the tunnel invert is typical. After PANDROL VANGUARD had been fitted the vibration in the tunnel invert decreased by 18dB averaged over the frequency range below 2.5 kHz. The response is relatively flat up to 500 Hz indicating that there is no significant track resonance. The small peak at 500 Hz is probably due to corrugations forming on the rail head. This is a phenomenon observed at a number of sites on the Victoria Line.

The street level vibrations were recorded in the early morning to minimise the effect of ambient noise in the street. Before PANDROL VANGUARD was fitted the vibration from both north and southbound tracks was similar at 76 dB. After PANDROL VANGUARD had been fitted to the southbound track the vibration from the northbound track was the same, but from the southbound track it had decreased by 7 dB and was only 1 dB above the background vertical vibration. This will be reflected in decreased vibration and hence noise in buildings.

These results show that PANDROL VANGUARD fastenings are a very effective

means of reducing the vibration from railway tracks in tunnels.

**FUTURE DEVELOPMENTS TO PANDROL VANGUARD.**

Many lessons were learned during the trial installation and these will lead to improvements to the design of the components and the installation equipment.

The main development effort is currently directed at a base plate version of PANDROL VANGUARD that can be used on existing sleepers. This will enable reduced noise and vibration to be achieved without major track reconstruction. ■



PANDROL VANGUARD track.

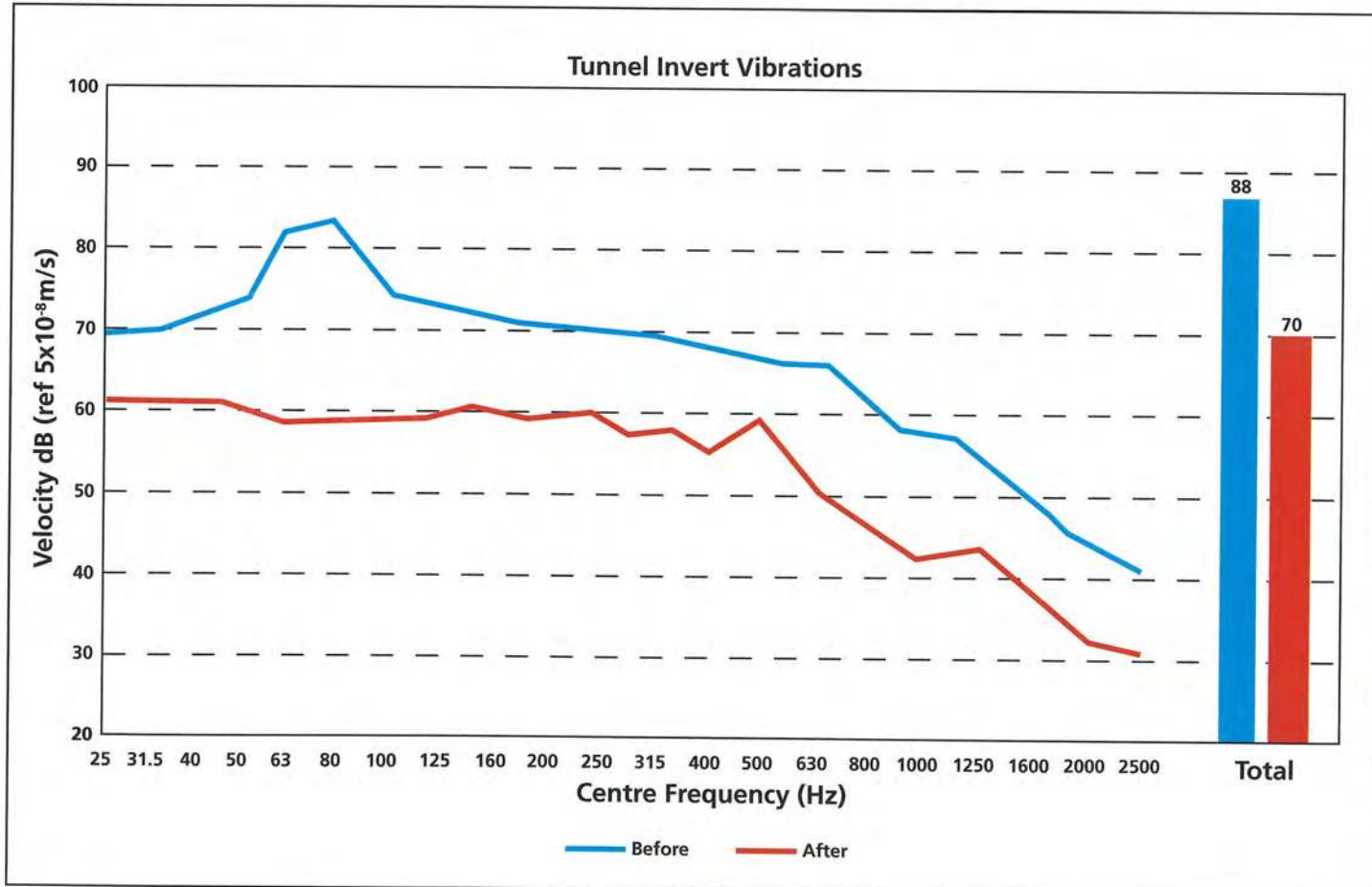

Tunnel invert vibrations.

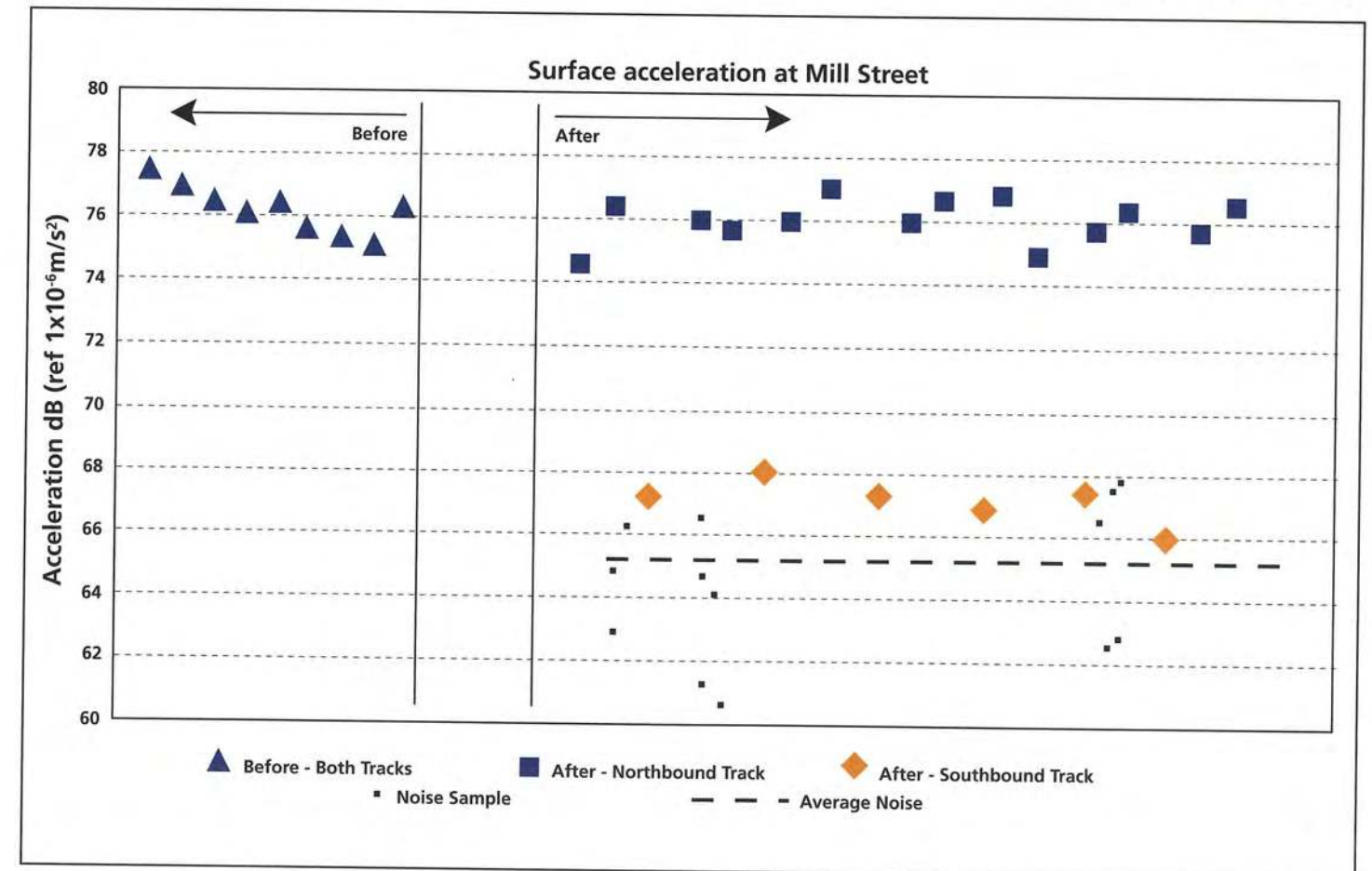

Street level vibrations.

# Vibration Isolation on Steel Bridge Structures - Solution for Manila's MRT Line 3

by Mr Mario C. Miranda, Project Director - EDSA MRT Project Management Office, Department of Transportation and Communication, Republic of Philippines.

The EDSA MRT3 Project for Manila's MRT Line 3 forms part of an integrated plan developed by the Government of the Philippines through the Department of Transportation and Communications to provide a network of light rail transit facilities throughout Metropolitan Manila (Metro Manila).

The project involves the construction of 16.9 kilometres of guideway with 13 intermediate stations and a depot.

The guideway consists of elevated concrete spans with longitudinal plinths to carry the track. The standard track fastening consists of discrete baseplate assemblies bolted to the plinth with a resilient layer between the plate and rail.

As a result of particular civil engineering and planning constraints, the standard track structure for the EDSA MRT3 could not be used at two locations - the Guadalupe intersection and Shaw Street station. For these sites steel bridges were required within the elevated track section.

Steel bridges are generally not favoured to support railway track, particularly continuously welded rail (CWR). The options available were:-

- A closed deck bridge with ballasted track and ballast walls at expansion positions. This is relatively inert for the track, but produces a very heavy structure and non-productive dead loading. Generally a somewhat inappropriate solution for a light rapid transit system.
- A light-weight open deck arrangement with rail bearers supporting the rails. Inspection and maintenance of the structure is more accessible than with the boxed-in ballasted track version.

For EDSA MRT3, the time constraints of construction and the need to have good maintenance access in limited maintenance work windows led to the adoption of the open deck arrangement.

Special consideration had to be given to addressing noise and vibration attenuation at this location, and the target for the track fastening assembly was to:-

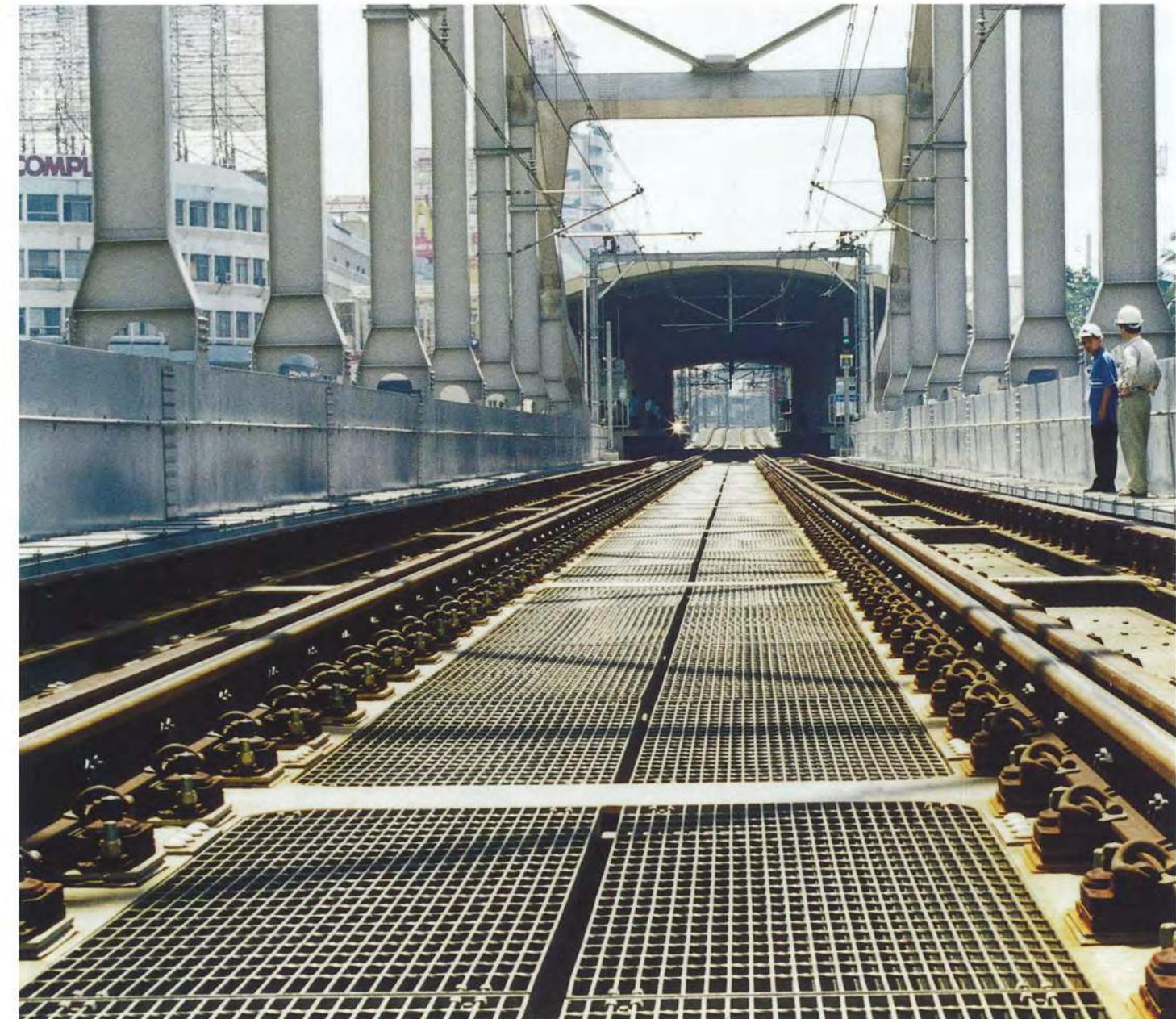

Open deck arrangement with rail bearers supporting the rails.

- Minimise the transmission of vibration from the rail to the structure.
- Provide the vibration attenuation capability within the top flange width of the steel bridge beams.

The PANDROL VIPA fastening system was chosen for direct fixation to the bridges and the final result is a good balance between relatively lightweight maintainable structures and a secure low maintenance, vibration attenuating track design.

The fastening assembly for the steel bridge had to conform to the general requirements as follows:

- The DFF / steel bridge assembly had to use the same Pandrol components as used on the other assemblies on the system, particularly

the Pandrol Brand e2043 rail clip.

- The DFF had to attach the UIC54 running rails to the steel flange of the bridge bearers, with full electrical insulation and lateral and vertical adjustment facilities.
- The fastening system had to:-
  - provide a longitudinal restraint force to limit a rail break gap to 75mm
  - be suitable for use at standard mechanical joints, mechanical insulated joints and glued insulated joints
  - be capable of withstanding repeated loading within the service conditions while maintaining gauge without fatigue failure or excessive maintenance of the fastening components
  - be composed of as few, easily identifiable parts as possible

- be designed to reduce transmission of vibration from the rail to the steel bridge
- be capable of achieving the full service life with no degradation of dynamic performance, including being subjected to the following environmental conditions:
  - Ultra Violet Radiation Intensity 800kJ/m<sup>2</sup> average per day
  - Ozone Atmospheric content: 100 parts / hundred million
  - Solvent: periodic dropping or spillage of solvents and oils from trains and track repair vehicles, including diesel fuel, lubricating oil and grease spillages

The PANDROL VIPA system economically provided all these features.

One novel aspect of the track construction,

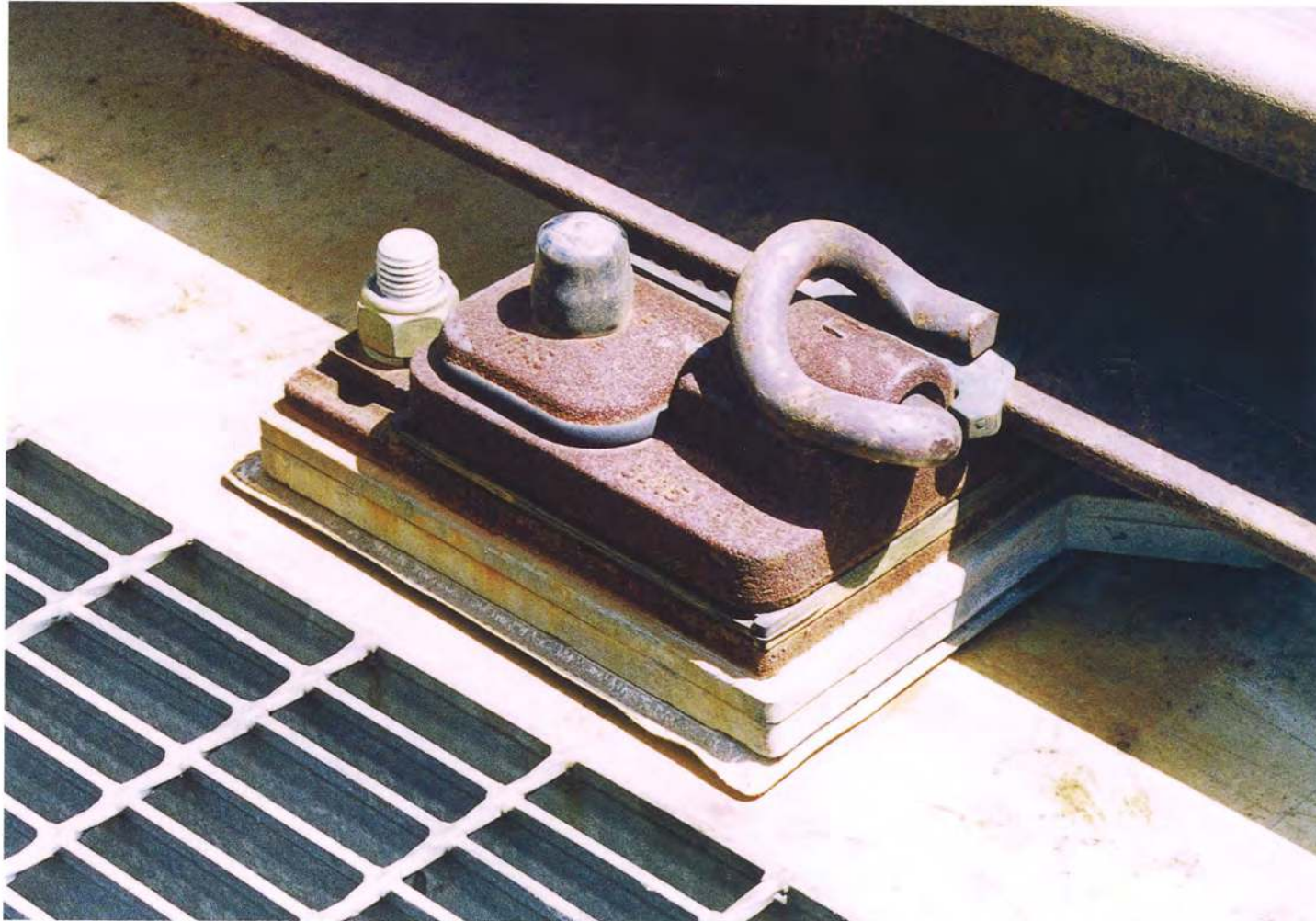

Assembly showing 'filler jacks' for levelling baseplates.

rarely used outside Japan, was the use of 'filler jacks' for levelling the baseplates. These products were developed from pumped and filled flat-jacks for bridge bearing work and consist of flat 'bladders' or 'envelopes' shaped to suit the baseplate plan area. The bladders are laid under the plates as flat plastic bags and pumped up with a resin filler material until they fill the void between the sub-structure and the baseplate.

Once cured, the resin provides a highly stable foundation for the plates and excellent track level can be achieved at each rail seat.

The technique is more expensive than using shims. However it has the advantage of being able to correct for cant deviations in the track sub-structure and compared with the practice of pouring individual grout pads in-situ, provides a very clean, accurate, fully filled support.

The photo opposite shows the finished bridge structure with the PANDROL VIPA plates in place.

The track has now been successfully commissioned and is already playing a vital part in Metro Manila's move towards an integrated transport system. ■



## G44 Dual Rail Assembly for Railtrack

by David Bateman, Principal Asset Manager (Track), Railtrack Asset Management.

### The need for a new sleeper

The UK railway infrastructure owner, Railtrack plc, began to consider the need for a new sleeper for two reasons: recognition of the fact that the use of a heavier rail section would yield economic benefits in terms of longer rail life and reduced risk of rail breaks, and pressure from train operators - especially freight operator English, Welsh and Scottish Railways (EWS) - for Railtrack to allow higher axle loads than the currently permitted 25 tons.

Railtrack decided early in 1999 that from the beginning of 2000, the standard EN 56E1 (formerly BS.113A) rail would be replaced by EN 60E1 (UIC60) for all main line re-lays. This would include the large West Coast Main Line re-construction programme, which has just

begun, and which will involve renewing most of the 600 route-km of track between London and Manchester, Liverpool and Glasgow. Having made that decision, Railtrack went on to specify new design criteria that would make the new sleeper a network-wide standard that could accept either 56E1 or 60E1 rail, and would be strong enough to withstand axle loads of up to 30 tonnes should future revisions of Railtrack's standards permit such an increase.

A further complication arose in evaluating the design requirements. As operation of faster trains (up to 225km/hr) on some lines makes any risk of tight gauge with 60E1 rail unacceptable, Railtrack decided to set the nominal track gauge with 60E1 at 1438mm, and nominal track gauge with 56E1 in the same sleeper at 1435mm.

To accelerate the change process, Railtrack's Track Asset Management team invited representatives of the concrete sleeper, steel sleeper and rail fastenings manufacturers to work with them, forming the Track Components Development Group. This group made full use of draft European standards to make sure that the new specification would meet all current and anticipated technical requirements, but also took into account experience from the supply industry members, including Pandrol, who had experience of track design for heavy axle loads in applications outside the U.K. Within the group, the product became known as the 'Future Proof Sleeper'!

The test regime for the fastening system corresponds in general terms to the draft



G44 sleeper with thicker side post insulator for 56E1 rail.



G44 sleeper for 60E1 rail.

European standard prEN13481:1999. However, the loads applied for the 3 million cycle durability test were increased to take into account the possibility of high axle loads. Calculations made by Railtrack and AEA Technology were verified by comparison with Pandrol data obtained from track tests in the USA to set the new test criteria. The specification also requires that the assembly conforms to prEN13481 (without the increased loads) when fitted with 56E1 rail.

**The G44 concrete sleeper**

The first concrete sleeper to be accepted to the new specification has been designated G44. This sleeper includes a PANDROL FASTCLIP rail fastening system adapted to give the dual rail configuration. By the end of 1999, Railtrack already had about 175,000 type F41 sleepers with PANDROL FASTCLIP FC1501 fastenings installed in track. The requirement to fit the 140mm wide 56E1 rail in a rail seat that would also accept 150mm wide 60E1 made it necessary to use thicker side post insulators with the narrower rail, and to extend the FC1501 clip by 10mm to reach over them and ensure design toe load was applied to the rail in all conditions and tolerances. The design of the new clip, designated FC1504, meant that changes were required to the shoulder design, and to the geometry of hand tools and other ancillary equipment. The project timescales meant that Pandrol had to complete all of these design changes, test the modified components and set up production tooling in less than six months. The project was completed on time, and the first G44 sleepers, with their fastenings pre-assembled, were delivered to the track laying contractor in December 1999.

In April 2000, the same contractor introduced the first track laying machine into the U.K. - a modified Fairmont Tamer P8-11, complete with FASTCLIP clip driving equipment. Previous attempts to bring machines of this kind into the U.K. had been abandoned because of tight structure clearance requirements, and short track possession times. However, the scale of new track upgrading projects in the U.K., including the West Coast Main Line, have provided the incentive for the machinery to be developed to suit the task.

**Further Developments.**

Work is now going on to develop switches and crossings - designated RT60 - to the same standards (i.e. with inclined 60E1 rail) as the G44 sleeper, and to develop a corresponding steel sleeper design (See Page 20) ■



Above: Modified Fairmont Tamer P8-11 track laying machine.



Right: Close-up of sleeper laying mechanism.



**Construction of the West Basin Intermodal Container Transfer Facility for the Port of Los Angeles.**

by Stephen C. Kapantais, Project Manager, Modern Continental.

Receiving containerised goods from cargo ships, identifying and transferring them to double stacked rail trains and delivering the goods to major cities throughout the US is a big part of railroad business today. The Port of Los Angeles has improved the intermodal facilities at their West Basin Site in San Pedro, CA to allow the transfer and double stacking of containers onto 6,000ft. long trains with a nearly seamless transfer of effort.

The newly constructed \$20 million improvement required 7.25 miles of new signal controlled tracks, 136RE CWR rail, concrete ties, 17 new motorised turnouts, 680 feet of precast tie-less grade crossings, 3 new structures with heavy loading design (Cooper E-80), and other roadway, civil, signal and mechanical improvements.

The lowest bid contractor, Modern Continental / Roadway is experienced in large

track and roadway construction projects. This experience combined with recent visits to several European track projects resulted in the selection of the PANDROL FASTCLIP as the fastener of choice. Seeing the construction methods employed on the new high speed rail link project connecting Arlanda Airport to central Stockholm, Sweden, secured the choice of 'rail ready' concrete ties. Combining rail readiness with a Rosenqvist rail clip machine,







Rosenqvist clipping machine.

track construction productivity was maximised.

Ordering, storing and transporting of rail pads, insulators and fastenings usually associated with concrete tie construction was eliminated. Lost or broken concrete tie components and tie materials were also eliminated as well as the need to order replacement parts.

MCC/Roadway contracted with CXT-Railroad Products Division of the L.B. Foster Company to manufacture concrete ties with PANDROL FASTCLIP materials totally pre-assembled on the tie. Field surveyors laid out the edge of the ties on the ground approximately every 25 feet on curves and 100 feet on tangents. The ties were then laid out on the prepared sub grade. Rails were then positioned on to the ties by use of a rail threader and the Rosenqvist clip machine squeezed FASTCLIPS from the parked position to their working position at a rate of between 5 to 15 ties per minute during initial installation. The clip machine has the capability to lift low ties up to the base of the rail, allowing clip positioning without additional labour which would otherwise be required to lift the ties.

The track was then flooded with stone ballast and positioned to final line and grade by

use of a Mark IV, high production tamping / lining machine. All ballast was regulated and swept to the final cross section requirements.

For thermal de-stressing of the rails, the Rosenqvist clipping machine repositioned the FASTCLIPS back to their parked position at a

rate of nearly 30 ties per minute. The rails were then heated to the required temperature, held in position with a 120 ton rail tensor, thermit welded, and then the clips were squeezed back to their working position at the rate of nearly 15 ties per minute. ■

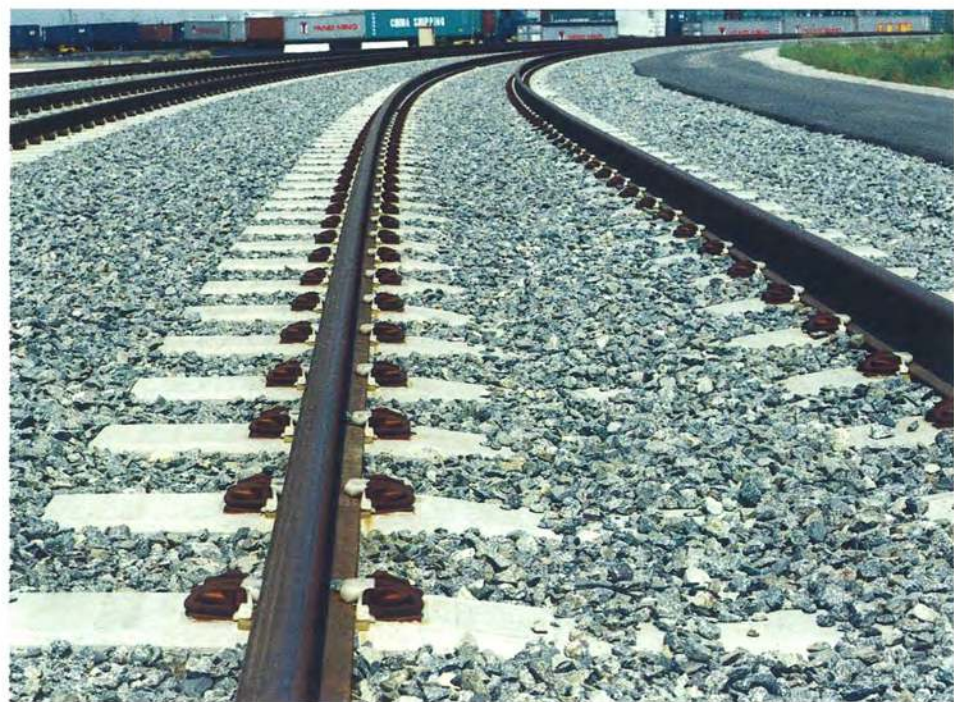

## Installation of PANDROL FASTCLIP Gauge Convertible Concrete Sleepers for TransAdelaide, Australia

by Terry Brady, Maintenance Manager Rail, John Holland Pty Ltd and Robert Schweiger, Projects & Administration Manager Track and Structures, TransAdelaide.

In July 1999 John Holland Pty Ltd was engaged by TransAdelaide to re-sleeper twelve track kilometres of the Outer Harbour line between Adelaide and Woodville, South Australia.

This line is a busy double track commuter line with 21.5 tonne axle loads, an annual gross tonnage of 3 MGT and maximum train speeds of 90 kph.

This project is part of a strategic investment by TransAdelaide to improve reliability, safety and economy of its passenger services by replacing timber sleepered track with a modern track form that will require lower levels of maintenance and provide higher levels of reliability and safety for the commuter services.

The PANDROL FASTCLIP system was selected by TransAdelaide to reduce the whole life cost of the system by reducing material handling problems during transport and placing, reducing installation time, and

providing fast and economical future rail relaying and destressing.

The project involved the removal of the existing broad gauge (1600mm) timber sleepers, excavation to allow adequate ballast depth and replacement with 17,500 gauge convertible concrete sleepers. The decision to choose gauge convertible sleepers provides TransAdelaide with future options to convert their system from 1600mm gauge to 1435mm (standard) gauge.

The work was carried out over a six week period utilising night possessions from 7:30pm to 5:00am. This arrangement allowed the line to re-open for peak services each morning, but required good planning and an intensive level of activity during the possession period.

The original track was continuous welded rail on plated timber sleepers with a mix of fastenings. Ballast depth was limited and the



finished rail level of new work could not exceed the original rail level.

Other interesting constraints included numerous busy level crossings and passenger platforms. The route, which covered six kilometres (dual track) between Adelaide and Woodville, included sections with close proximity to suburban residential housing.

An additional, unexpected problem was quite a lot of wet weather.

The combination of John Holland's motivated and dedicated team, the Pony tracklayer, excellent support and cooperation

from TransAdelaide and careful planning, ensured the project was successfully and safely completed.

It was the first time that John Holland's Pony tracklayer (which was designed by Valditerra Lavoria Ferriviari S.p.A. of Italy and manufactured by Fairmont Tamper) had used the PANDROL FASTCLIP system on concrete sleepers and from the outset the advantages were evident.

Sleepers were loaded onto the sleeper wagons from TransAdelaide's stockpile at Dry Creek (approximately ten kilometres from

the site). The sleepers were manufactured, and PANDROL FASTCLIP components pre-assembled by Austrak in its Geelong Victoria factory prior to transport to Dry Creek.

Once loaded, the sleeper wagons were moved to the site and connected to the Pony tracklayer. The Pony tracklayer was then 'fed' the sleepers from the sleeper wagons by means of the sleeper gantry.

The Pony tracklayer uses its unique hydraulic grab system to move the tracklaying train forward as it splays the rail to each side, picks up the used timber sleepers, prepares the

ballast bed and lays the concrete sleepers.

With other fastening systems, pads would be placed on the sleepers while they are on the sleeper wagons, a labour intensive task requiring the gantry to slow its operation.

With the PANDROL FASTCLIP system the sleepers were delivered 'ready to lay' eliminating labour, accelerating the process and improving quality.

Rail was threaded onto the sleepers behind the Pony and the FASTCLIP fastenings moved into final position using mechanised clip driving machines (Geismar AP11) and hand tools, where required.

The PANDROL FASTCLIP system eliminated the need for handling individual jewellery items (pads, clips, insulators) resulting in cost and time savings, elimination of manual handling risks and improving the quality of the finished track.

Without the need to assemble loose fastening components during these night possessions tracklaying was more efficient under the reduced light conditions.

Apart from minor modifications to the Pony feed mechanism (to accommodate the longer gauge convertible sleepers), no other major changes were required to the tracklaying operation. As with most new systems some improvements were identified early in the project. These improvements included changes to some of the hand tools and establishing more efficient work methods to adapt to the PANDROL FASTCLIP system.

After final tamping, lining and regulating of the track, the rails were adjusted to a neutral temperature of 38°C converting the track to continuously welded rail. The destressing process was straightforward with the PANDROL FASTCLIP fastenings moved to the parked position by using mechanised and manual tools, allowing the rail to be destressed then pretensioned prior to welding. The FASTCLIP fastenings were then re-installed into their working position, completing the process.

The tracklaying team found it to be an advantage to have a well-prepared ballast bed when laying the sleepers prior to positioning the rail and fixing the clips.

Since the work was completed in November 1999, the track has performed well showing improved stability during summer months and retaining good geometry. The success of this project has given TransAdelaide the advantages and confidence to proceed with further PANDROL FASTCLIP investments over the coming years. ■



John Holland's Pony tracklayer.

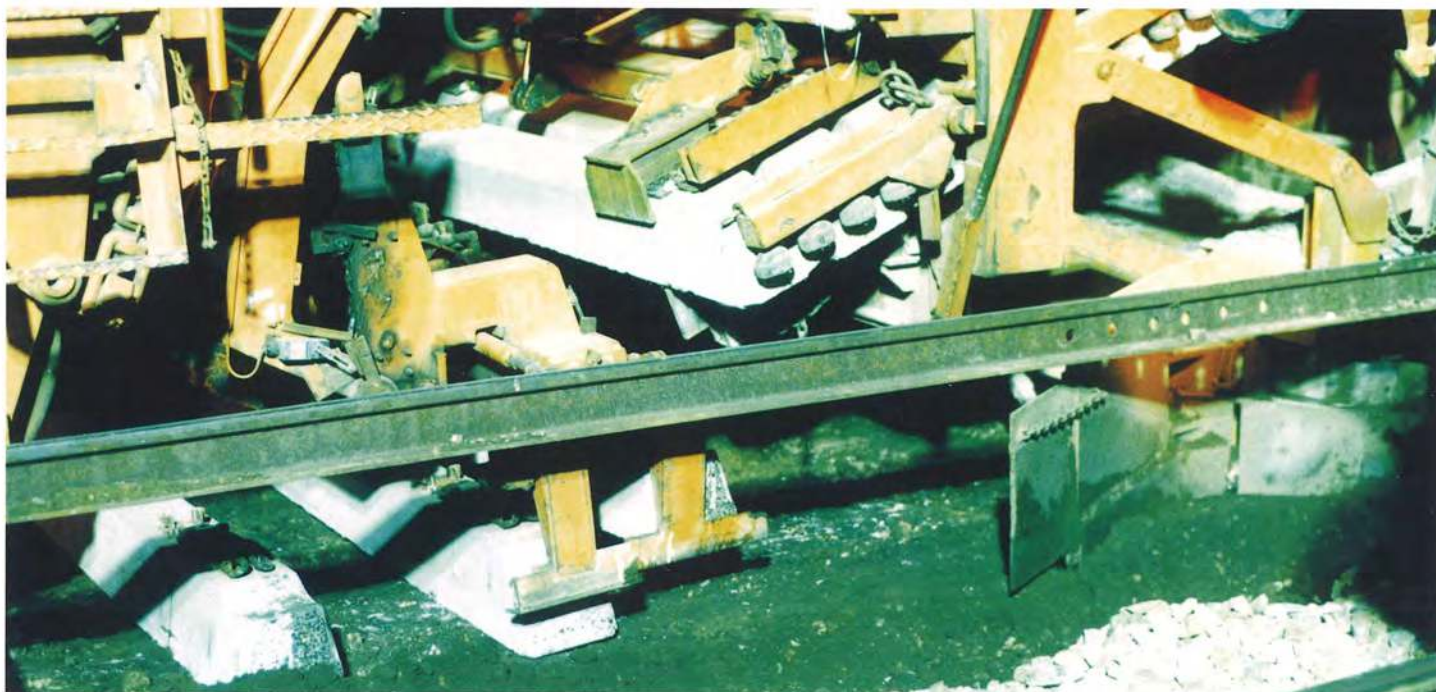

Close-up of sleeper laying mechanism.



# PANDROL FASTCLIP on Steel Sleepers in the UK

Following a series of extensive tests and a track trial in late 1998, volume deliveries to Railtrack of steel sleepers fitted with the PANDROL FASTCLIP system have just begun.

Steel sleepers themselves are not a recent invention. In Africa and the Indian sub-continent in particular, the use of timber had for long been impractical, not because of timber shortage, but because of problems such as termite attack. Steel sleepers were easy to import due to their low weight and bundled volume. Consequently millions of steel sleepers were laid from the late 19th century onwards and they performed extremely well. More recently, as concrete sleepers have been adopted elsewhere in the world, steel sleepers have still been used in many of these countries, as they are lighter and easier to handle.



Figure 2 - FASTCLIP attached to steel sleeper by Huck bolt.

which rested the rail. On another type, the chair was cast directly onto the top of the sleeper. Molten metal would flow through two holes under each chair position and form heads on the underside. In some cases mild steel chairs were welded on. Compared to early concrete sleepers, steel was easier to handle. However, throughout the 1950's the machinery to handle the heavier concrete sleeper was improved and steel lost some of its advantages in the UK.

It was not until the late 1980's that the use of steel sleepers in the UK began to rise again. Increasing pressure to reduce costs led Track Engineers to examine the merits of steel sleepers once more. The resurgence of steel sleepers in the UK began in the Manchester area. Again one of the major problems to be solved was how to attach the rail to the sleeper. By this time of course bull-head rail and cast iron chairs were obsolete in the UK. Conventional 'Flat bottom' rail fastened by PANDROL clips was standard and a suitable way of fastening the PANDROL shoulder to the sleeper had to be found. Four



Figure 3 - FASTCLIP steel sleepers being laid by hand at Thetford.



Figure 1 - Steel sleepers being installed during 1946.

In the UK, shortly before World War II, timber shortages led to the experimental introduction of steel sleepers. Installations continued after the war and Figure 1 shows a 1946 installation in progress. The sleepers at this time were made of 5/16" or 3/8" plate with a beaded edge, pressed into the form of an inverted trough, the ends being closed off to provide lateral resistance. As British Railways still used bull-head rail at that time, a way of fastening cast iron chairs to the sleeper had to be found. In some cases the chairs were formed by pressing up pieces of the trough to form the chair jaws, a loose plate being provided on



Figure 4 - FASTCLIP steel sleepers being laid by hand at Downham market.



Figure 5 - Rail being installed into FASTCLIP steel sleepers on the Settle to Carlisle line.



Figure 6 - Road-rail module clipping up FASTCLIP on steel sleepers.

Railtrack, seeing the economic benefits that FASTCLIP gave on concrete sleepers asked Pandrol to establish whether a suitable way of attaching the FASTCLIP system to a steel sleeper could be found. A number of alternatives were examined and two solutions emerged that involved mechanical fixing of the shoulder to the sleeper either by means of a compression fastening, such as a Huck bolt (see Figure 2), or by means of a modified hook-in shoulder. It was decided jointly by Railtrack, Corus and PANDROL that the new sleeper be put through the full European Testing Standard for Rail Fastenings, EN13481-4:1999. This involves carrying out a number of tests including creep resistance, electrical insulation and - by means of a 3 million

cycle inclined repeated load test - durability. Once the test programme had been completed, Railtrack Product Acceptance was granted.

The first track installation was arranged by Railtrack East Anglia Zone in conjunction with Centrac a major UK track contractor. 280 sleepers were installed on a freezing December night in 1998 at Thetford in Norfolk. Figure 3 shows the sleepers being laid by hand, the quality of squareness and alignment being maintained by use of the 'Zimmer Frame' shown in blue. Clipping up was with handtools. The whole installation was clipped up in 30 minutes much to the satisfaction of the contractor. The track was destressed one week later and the captivity of the system won many friends among

the contracting crew.

The next major installation, this time of nearly 6,000 sleepers, took place again with Centrac at Downham Market, Norfolk. Figure 4 shows the sleepers being installed by hand. Figure 5 shows the rail being installed on a further installation of 1300 sleepers on the famous Settle - Carlisle line at Crosby Garret.

The use of machines is now well established for the lifting and clipping of concrete sleepers. These benefits are now being extended to steel. Successful tests have already been carried out using a road/rail attachment manufactured by AWI of Sweden, (see Figure 6) and a magnet pack option is available for Pandrol's own range of machinery. ■



Completed track at Thetford.

# New Patented Systems for Locking Shoulders into Sleeper Moulds

by Franco De Cicco, Managing Director, S.I.C.I.

S.I.C.I., an Italian company based in Forno Taro (Parma) - Italy has been engaged in the design and realisation of moulds and complete plants for the production of prestressed concrete railway sleepers for over 15 years. Thanks to its consolidated expertise, S.I.C.I. has been chosen as a partner in the realisation of 'turnkey' factories all over the world, for example in Italy, Germany, Spain, Colombia, Brazil, Korea, Indonesia, Hungary, Great Britain and Malaysia. S.I.C.I. produces equipment for the production of prestressed concrete railway sleepers by either the Long Line or Carousel system.

The concepts which have always characterised S.I.C.I.'s plants relate essentially to the flexibility of the equipment; all the moulds, except for different and specific requests of the client, are equipped with plates in the rail seat areas, which are bolted into the mould and are easily interchangeable. This means that should it be necessary to change to a different shoulder type, then this can simply be carried out by replacing the rail seat plates.



Detail of an EVOLUZIONE locking system seen from the bottom of the mould.

The interchangeability of the rail seat plates is a concept that is available for either the Long Line or Carousel systems.

The latest significant project has been the involvement in a new plant for Vianini S.p.A., Italy, capable of producing 2,400 sleepers per day.

In Vianini's factory in Italy all the moulds for the production of the Italian State Railways type 'FSV35P' sleepers, were supplied with interchangeable plates with pockets to accept a 12mm pressed steel Pandrol shoulder.

The principle of the new system introduced by S.I.C.I. and named 'Evoluzione' (patent pending) is that each pocket incorporates a special built-in shoulder locking system making it unnecessary to use external locking systems, such as the multi-spindle arrangement commonly referred to as the 'Christmas Tree'.

Each plate is independent as it relates to the shoulder anchoring system and to any adjustments during the installation phase.

The experience in Vianini's factory, after production of more than 200,000 sleepers, was found to be particularly effective both concerning the dimensional tolerances achieved in the sleeper and its reliability: the percentage of rejected sleepers being in the order of just 0.1%.



Plate with 'Evoluzione' locking system.

The 'Evoluzione' system can be used for both pressed steel and ductile iron Pandrol shoulders; each pocket features a special anti-oil rubber seal to contain the grout, and to absorb shock, which is desirable during the stress transfer phase.

Based on the same concept, a new S.I.C.I. system named Fast Lock, for securing PANDROL FASTCLIP shoulders has now been developed; this system (Patent Pending), evaluated both in Malaysia and in Italy, is conceptually similar to what S.I.C.I. used in the 'Evoluzione' 'e' Clip shoulder project.

In this case also, the plates incorporate a built-in anchoring system for the FASTCLIP shoulder and an anti-oil rubber profile in order to prevent grout leakage.



FAST Lock plate.

Both shoulder fixation systems are characterised by the speed and cost effectiveness of interchangeability, should that be necessary, but primarily the success of the concept has been in its precision and adjustability of the shoulder positioning.

In both systems, the action of pushing the shoulder from the outer side guarantees shoulder location in the defined checking position, whatever the tolerances in the shoulder itself.

Particularly significant is the fact that in both systems, in spite of the very tight tolerances imposed by the Italian State Railways (FS) (+/- 0.5 mm between the two adjacent shoulders) a percentage of rejected sleepers near to zero has been obtained.

The Fast Lock system has also been tested, with very good results, in the production of FASTCLIP concrete sleepers by the Instant Demoulding system; both the 'Evoluzione' and Fast Lock systems can be easily adapted to suit existing concrete sleeper moulds. ■

# The Øresund Link Railway

by Konrad Hove, System Manager, Railway Øresundsbro Konsortiet.

In 1991 the governments of Denmark and Sweden decided that a fixed Link should be built to connect Copenhagen with the major city of southern Sweden, Malmö. It includes a four lane motorway and a double track railway. It was decided that the railway should be designed for high speed, 200 km/h, and allow for trains passing between Danish and Swedish railway systems without speed reduction.

The railway systems of the two countries differ in almost all aspects: signalling systems, interlocking and ATP systems, high voltage and frequency, train radios, etc. and even the languages represent a big challenge.

The distance between the two shores is approximately 16km. The Link includes an artificial peninsula, an immersed tunnel, an artificial island, named Peberholm, and a bridge. Steepest gradient is 1.56% and this is used on the approach bridges that climb up to the high bridge where there is a passage for ships up to

55m high. In the tunnel the railway runs in two single-track tubes. The track construction in the tunnel was designed as a slab track, thereby reducing the height and the cost. On the bridge the railway occupies the lower deck.

Because of all the differences a system border was introduced on Peberholm. On the western side of the system border traffic is controlled by Danish dispatchers, using Danish train radios, and a Danish interlocking system connected to Danish ATP transponders which control train speed, while switches in the overhead contact wire are remotely controlled by the Danish high voltage operators. East of the border Swedish systems and staff carry out corresponding activities.

The signalling systems are different in a way leading to dangerous situations. One green light in Sweden means that you may proceed at full speed, while in Denmark it means that a stop signal must be expected. Swedish drivers

in Denmark could very easily go too fast if they based safety on reading external signals. Consequently it has been decided that an ATP system is needed as the primary background for safe movements. Should the ATP system fail only very low speed is allowed.

As the ATP systems are different, a new system was needed. The two major operators, DSB and SJ decided in 1996 that a combined Danish/Swedish ATP system should be designed. A data bus and a system selection panel were developed, and the software in both systems had to be revised. This combined system is very complicated as it must allow for travelling in both countries with an automatic change over and ensure that no reduction of safety occurs when it is used in either country.

The system has been tested in different vehicles. Electro-Magnetic Compatibility problems have occurred. The bursts from high voltage switches and the passage of iron constructions



Øresund train unit passing the toll station for road traffic, which is located in Sweden, half a mile east of the bridge.

close to the antennas have led to 'ghost transponders'. The Danish part of the Combined ATP system was designed for temperatures down to minus 25 degrees. However trains going north of Gothenburg need to resist temperatures down to minus 40 degrees. A simple solution to that problem has been found.

The languages are different, so a vocabulary has been developed, including some 150 railway terms. A few words can not be translated by a single term, because they relate to procedures with no similarities. All figures should be said digit by digit. In general you speak your own language, slowly and distinctly. But the above

railway terms should be translated. A point is 'växel' in Sweden and 'sporskifte' in Denmark.

The safety regulations are different, so training was needed. A 4 week course for train drivers is used. Swedish drivers are trained using the Danish language and vice versa. Thereby they are learning the language and the regulations at the same time. Additional courses have been arranged for traffic dispatchers, maintenance staff etc.

One critical point is the interconnection of Danish and Swedish interlocking systems. A special interface unit has been developed to transfer information from one system to the

other taking into account that regulations, signals and ATP telegrams are different.

All trains must be equipped with Danish train radio linked to the ATP computer and Swedish train radio following the new GSM-R standard. The channels in the Danish train radio are shifted automatically by ATP transponders thereby ensuring that the driver is always connected to the dispatcher in charge of his actual location.

The Danish power system standard with 25kV and 50Hz was extended to the Swedish shore, where it has been separated from the Swedish standard 15kV and 16 $\frac{2}{3}$ Hz by a neutral

section. The contact wire - and all other electrical equipment - can be fed from both sides. This leads to a high reliability. All electrical trains and locomotives must be equipped with a dual power system.

All contracts were made as 'design and build' contracts. The tunnel contract included the track in the tunnel, designed by Sonnevile International on behalf of Balfour Beatty. The remaining track system was designed by the 'railway contractor' Banverket Industridivisionen. Both contractors have chosen the PANDROL FASTCLIP. On the Danish landside, PANDROL FASTCLIP FC1501 for UIC 60 rail is used on concrete sleepers in ballast with 1:40 rail inclination. Across the bridge the same trackform was chosen with the standard Swedish rail inclination 1:30. The difference in rail inclination is not expected to cause any problems. For the tunnel, rubber booted Sonnevile LVT blocks with FASTCLIP FC1501 rail fastenings have been laid. Due to corrosion risk, the shoulders were galvanised and the clips sheradised. The rail inclination is 1:40. The track standard allows for an axle load of 22.5 tons at 200km/h or 25 tons at 90km/h.

Obtaining a mutual understanding in two countries has been a big challenge, but test runs have been successfully completed and the railway was opened for commercial services on 1st July this year. ■



Rubber booted Sonnevile LVT blocks with FASTCLIP FC1501 rail fastenings.



Train units run on the lower deck of the bridge.

## Development of the Lock-In Pad

During discussions with the construction groups looking at the proposed 1400km Alice Springs to Darwin railway line, Pandrol was requested to design a specific FASTCLIP track fastening system for the project.

It had become clear that the PANDROL FASTCLIP captive fastening system would offer large benefits to the track construction groups, not only in terms of providing for fully automated track laying in extreme climates and remote areas, but also in removing the logistics of transporting and co-ordinating the supply of loose components over long distances.

A requirement of this project is that the majority of the line will be non-insulated, thus not requiring either toe or sidepost insulators. A rail pad is however required to provide a conforming layer between the rail and the concrete sleeper.

The PANDROL FASTCLIP system had to be redesigned to dispense with the insulators but still provide the fully captive, 'rail ready' features that have made the product so successful to date.

By adapting the standard FASTCLIP pad, shoulder and clip, a secure non-insulated assembly was developed, allowing concrete sleepers to be 'dressed' in the factory and transported long distances with no component movement.

The system has so far been developed for HDPE pads with design work continuing for other pad materials. The new 'lock-in' rail pad has specially designed tabs that deflect to lock into pockets in the cast shoulders.

This design can be applied to all Pandrol concrete sleeper fastening systems where a captive pad would prove advantageous.

The accompanying pictures illustrate the 'lock-in' pad feature modelled on Pandrol's 3D CAD system. ■

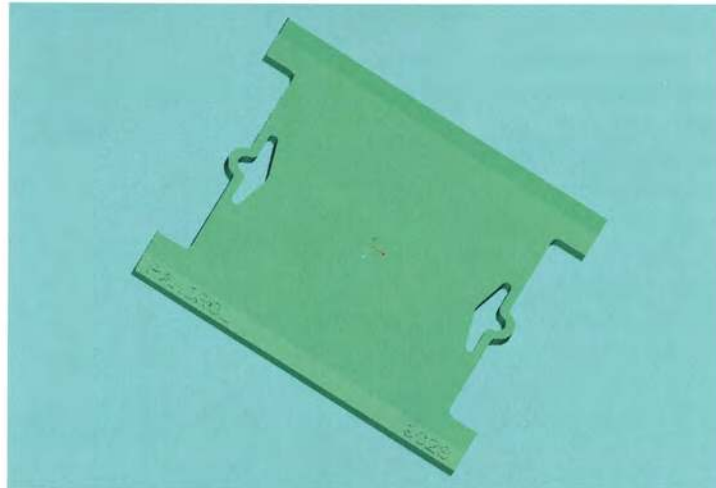

3D CAD model of Lock-in Pad.

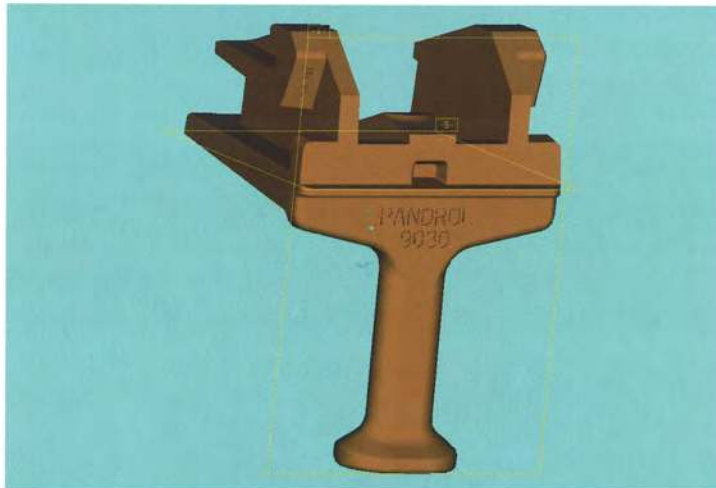

3D CAD model of adapted FASTCLIP shoulder.

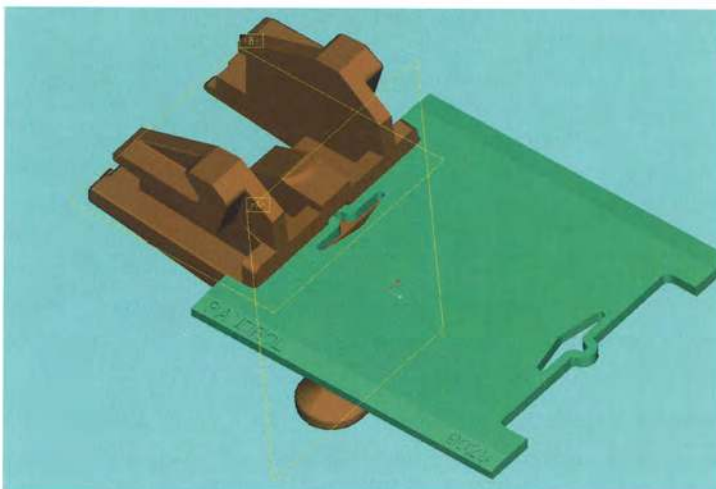

Captive Pad - locked into features on the shoulder.



PANDROL FASTCLIP FD 1300 installed on rehabilitated steel sleepers on the Hanoi to Ho Chi Minh City Line in Vietnam. The FD 1300 system is the latest in the FASTCLIP family of products providing a commercially attractive solution for less intensively used track or for lighter axle loads.