

2016

TRACK REPORT

The Journal of PANDROL
Track Systems



 **PANDROL**
TRACK SYSTEMS

© DELACHAIX GROUP

PANDROL FASTCLIP

Borders Railway Project	03
Renewing Caersws to Newton in a Hard Days Night	05
FASTCLIP and TRS4 take Polesworth to 80 mph	07
Enhancing Gar Bov's Rail Infrastructure with FASTCLIP	10
Refurbishing Dorset's River Stour Bridge	14
Refurbishing Dorset's River Avon Bridge	16
Saving Chorley Tunnels Historic Arch	18
Globe Trotting CD400 Clip Driver ready for UK	20

Projects

Introduction to Plastic Baseplate Assemblies for Urban Transit Systems By Philippe Matuch	21
Connecting Two Holy Cities	23

Direct Fixation Assemblies

Vanguard Retrofit solves noise problem for London Underground	24
Silencing the Golden Horn Bridge	27
Klang Valley MRT Line 1	29
VIPA DRS technology for UI Metro in Seoul	32

PANDROL Innovations

Product Round-up	34
-------------------------	-----------



Team work makes lean work of Borders Railway project

When Network Rail Scotland needed a new fastening system on the Borders Railway, the PANDROL team had a major challenge on their hands. While most of the track was fairly standard, the short tunnel between Stow and Galashiels was far from it.

The Borders Railway was being reopened with funding from Transport for Scotland, with Network Rail Scotland leading the design and build from their Glasgow head-quarters. The old Waverley route, which closed in 1969, leads south from Edinburgh Waverley station towards the Scottish Borders, through Galashiels. It terminates at Tweedbank, just north of Melrose.

While many of the original structures and empty track bed remained, some significant new structures and alignment were needed on the southern outskirts of Edinburgh. Network Rail Scotland decided to use a single fastening-type along the whole length of the newly relaid track, both on and through the structures. A single fastening makes operations smoother by needing fewer spares and fewer tools.

The majority of the track is plain line ballast with Type G44 concrete sleepers, which use the PANDROL FASTCLIP system fastening. FASTCLIP was therefore preferred for the whole route.

The biggest challenge for PANDROL was the tunnel between the towns of Stow and Galashiels. PANDROL had less than 8 months to finalise the design and complete testing and production tooling. PANDROL also had to supply the new system to the sleeper maker, RAIL.ONE of Germany, to be included as part of the cast-in sleeper package for the RHEDA 2000 slab track system.

The Bowshank tunnel is cut through a promontory of rock, around which the Gala Water river negotiates a tight bend in the valley floor. The tunnel is aligned on a tight horizontal curve of 500-metre radius for the twin tracks, which form a passing loop in the mostly single-track route.

The modern requirements for extra trackside equipment in the tunnel, together with the need to increase the line speed above the original Victorian design, meant that extra dynamic gauge clearances were needed. This could only be achieved by lowering the level of track inside the tunnel by 600 mm.

In order to fix the track into this tight envelope, the team had to use a concrete slab track to achieve the higher cant and cross fall to allow good drainage, while maintaining the tunnel clearances.

Network Rail Scotland chose the RHEDA 2000 system and the PANDROL FCA system (the 'A' is for adjustable), which enabled mostly interchangeable components and standard tools, necessitated a rapid programme of tooling, inspection, testing, fit and function assembly with the sleeper maker in Germany.

The PANDROL team moved into action in November 2013, placing orders for the new designs with specialist suppliers and preparing for final laboratory testing. By the end of August 2014, the track in the Bowshank tunnel was complete and awaiting connection to the ballast track at both the northern and southern portals. How was this achieved so quickly?

The normal time for tooling was accelerated by rapidly producing low volume tooling, sufficient for the short length of the track in the Bowshank tunnel. First samples were therefore available for the initial assembly trial in Germany in January 2014. The fit and function assembly comprised a short track panel of 6 sleepers, and 3.2 metres sections of size 56E1 rails, specially taken to the RAIL.ONE sleeper factory outside Dresden. The PANDROL team transported the rail in the PANDROL Track Support van, driving the 1,500 kilometres to Dresden from Worktop, together with all the tools needed for rail handling and clip installation. Measuring equipment was used to apply the correct torque to the bolts and adjust the track gauge.

After the success of the first assembly, the production phase moved ahead immediately. All PANDROL 'FCA' components were dispatched to Germany for assembly with the sleepers. Sleeper production commenced in February and ran to the end of April. Sleepers were dispatched to site at the end of April.

The main contractor was BAM Nuttall, a company familiar with the PANDROL FASTCLIP system for ballast track as delivered on the Type G44 sleepers. Whilst many of the components and the appearance of the PANDROL FASTCLIP 'FCA' system is almost identical, some significant differences in the site methods are necessary to install this slab track. This prompted the PANDROL support team to visit the site in order to brief the installation gang.

Using the sleepers previously delivered to site, the briefing and demonstration took place in mid-July just prior to the programmed start of the track installation in the tunnel. A track training panel was created and 20-metres rails were used to create the track. The panel was used to demonstrate the latest installation and extraction tools, which work for both standard FASTCLIP and the new 'FCA' system. Rail turning bars and sleeper lifters were also demonstrated, so that best practice for handling and accurate positioning of the rail could be highlighted.



The installation of the track in the tunnel, and the pouring of the mass concrete track panels, preceded at an accelerating pace as the track team gained experience and confidence. The whole of the track in the tunnel was completed by the end of August.

The PANDROL team returned to the site twice more, halfway through the track laying and after the concrete slab track was completed. The final installation produced an excellent alignment through the tunnel. The track is tightly curved and canted about 100 mm, so the final job shows adjacent tracks: separately canted and split

by a central drainage channel. The clips and shoulders both feature a Sherardised finish for corrosion protection in the wet tunnel, which has been known to flood. The worst recorded flood was in 1891, when the track was submerged in 300 cm of water from the Gala Water river.

The track commenced its first commissioning runs early in 2015, and train services began on 3 September 2015. The Borders Railways had returned, and thanks to great teamwork it had arrived in good time.



Renewing Caersws to Newtown in a hard day's night



These photographs show the work carried out on the night of 21 March 2016:

PANDROL FASTCLIP enabled a 300-metre track renewal between Caersws and Newtown, as part of a major route improvement on the Welsh west coast. Babcock Rail was the main contractor, supported by McCulloch Rail who conducted rail threading. The renewal was carried out during a night track possession between last and first trains.

Traditionally, single line route renewals are carried out during weekend possessions. The methods used by PANDROL at Caersws prove significant lengths of track can be relaid during mid-week, night-time possessions. This allows daytime train

services to run uninterrupted. To meet such tight deadlines, PANDROL and our partners used a combination of steel sleepers and a highly skilled track team. All processes ran sequentially, from track removal to clipping up.

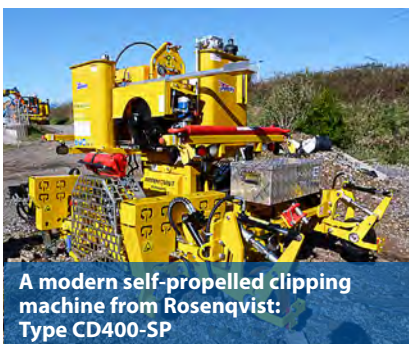

A modern self-propelled clipping machine from Rosenqvist: Type CD400-SP



Caersws station

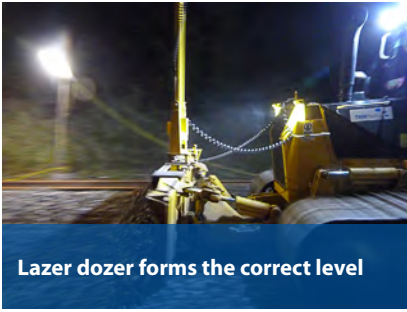

Lazer dozer forms the correct level



Checking the alignment from fixed survey points



Painting a guidance line on the ballast



Rail threading using a McCulloch TRT



Cutting the rails with abrasive disc

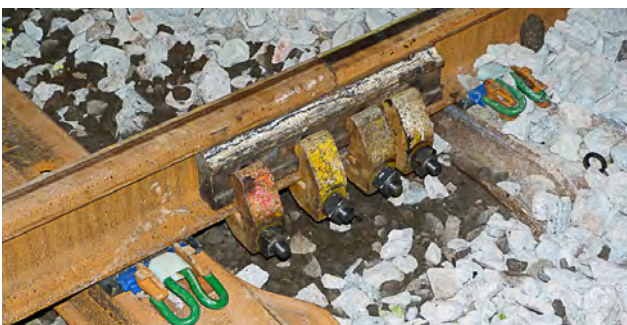

Temporary rail clamps at the joints



Train awaits to drop the extra ballast

Renewing 300 metres of single line track in mid-week, night-time possessions is feasible using steel sleepers. These traditional methods, carried out by an experienced track team, allow for repeatable operations each night. Normal train timetable service continues during the day. Operations follow a sequence of cutting the track, removal of track panels, scarifying the old ballast, laser dozing, laying sleepers, sleeper alignment, rail threading, temporary joints, clipping-up, dropping top-ballast, and tamping. Rail stressing is carried out during a separate possession.

Steel sleeper section supplied by Tata Steel. Sleeper fabrication completed by Trackwork Ltd (formerly known as GMT).

FASTCLIP & TRS4 take Polesworth to 80mph

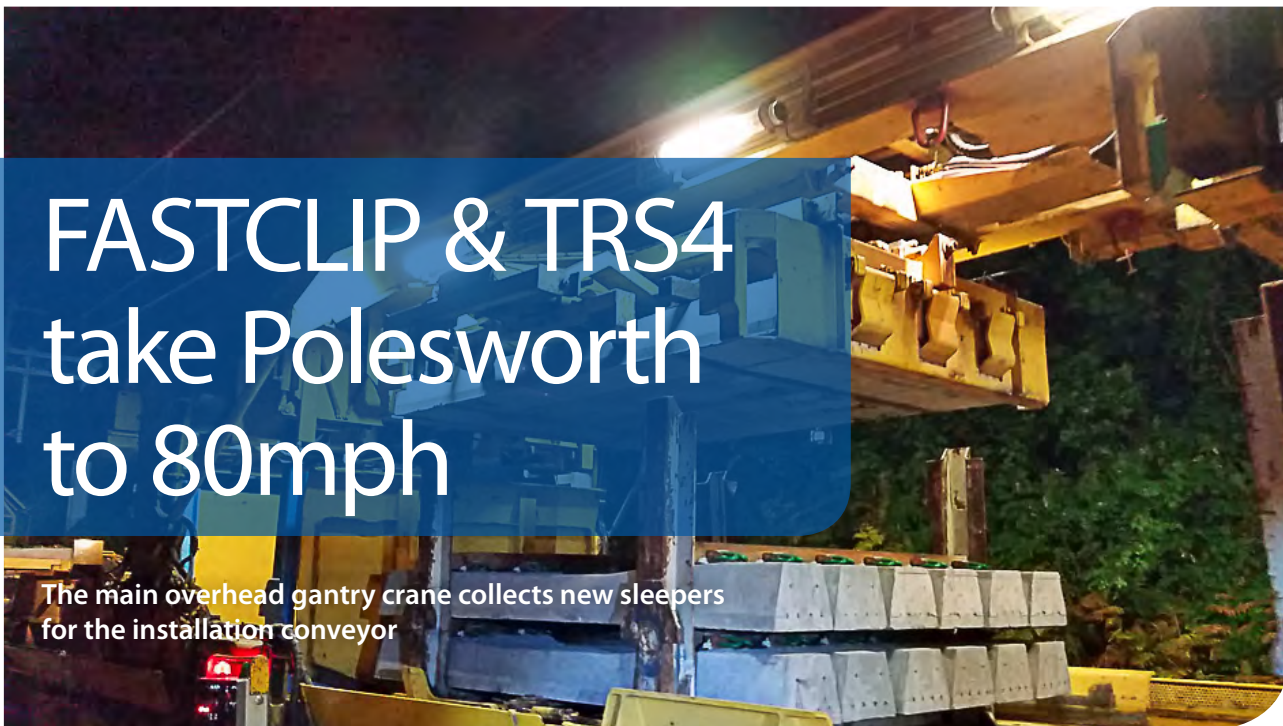

The main overhead gantry crane collects new sleepers for the installation conveyor



PANDROL FASTCLIP FC fastenings and the TRS4 machine were used in the renewal of 480 yards of rail track at Sandyways, near Polesworth, West Midlands, UK. The renewed line features Type G44 concrete sleepers and size 60E1 rail, and is now capable of speeds up to 80 mph.

Once cut-in, a TRS4 machine relays track at a rate of over 400 sleepers per hour throughout the nightly possession hours.

G44 concrete sleepers are dual-rail capable for either 60E1 or 56E1 rails. They're delivered to site with components already attached, ready for clip insertion with automated machines.



The delivery gantry crane collects new sleeper pallets for sleeper exchange deck



Site access location

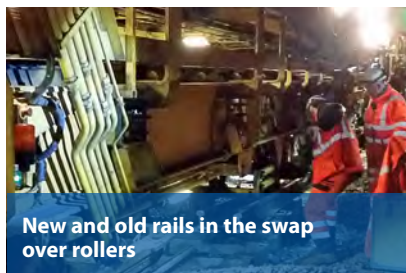

New and old rails in the swap over rollers

The whole process was completed on Monday 27 July 2015, between 10pm and 6am.



Threading in the new rails



Clipping module behind the old rail, threaded away from the new sleepers with the new rail



Ballast profile blades remove excess ballast



The ballast regulator removes, cleans, replaces and compacts the ballast around the sleepers



The tamper plunges vibrating tines into the ballast and squeezes the stone under the sleepers



Final revolving brooms remove ballast from the around the fastenings



The sleeper delivery gantry in the foreground with the main sleeper exchange gantry in the background



The TRS machine seen during daylight hours showing the overall length with sleeper wagons

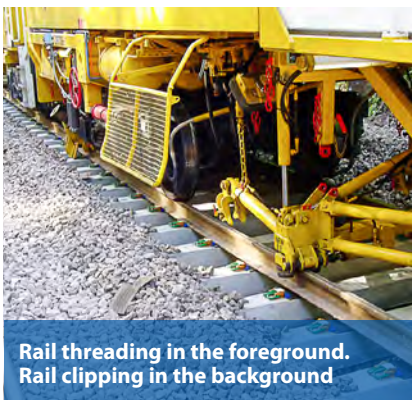

Rail threading in the foreground. Rail clipping in the background



The sleeper wagons and steel pallets with new sleepers, for exchange with old sleepers

A TRS machine in daylight reveals the length of the 'factory on rails' that exchanges old track for new sleepers and rail. The machine can lay track at a rate of 7 sleepers per minute.

The G44 sleepers pictured above feature mauve-coloured FASTCLIPs, with a Sherardised finish to protect against corrosive environments.

Enhancing Gara Bov's rail infrastructure with FASTCLIP



Following the success of a small trial of 267 sleepers at Gara Bov in 2012, a request for a larger installation of PANDROL FASTCLIP FE1408 assemblies was initiated by the National Railway Infrastructure Company (NRIC), Bulgaria's state-owned railway infrastructure company.

The assembly selected was an FE-16673 Gauge Widening assembly, which is supplied with a 14 mm collar on the field side and 6 mm collar on the gauge side. This allows for a total gauge widening of 16mm across both rails. The components were supplied pre-assembled on to monoblock concrete sleepers.

The existing track to be replaced had K-plate fastenings secured on wooden sleepers, between Anton Station and Pirdop Station. The line consisted of 6.2 km of single track, with a minimum curve radius of 500 m.

The new concrete monoblock sleepers were manufactured at the ZPSV factory in Varna, located on the east coast of Bulgaria and approximately 400 km east from Anton Station. ZPSV use a typical 'Carousel' method for producing sleepers.



Panel Layer

As part of a joint development agreement between PANDROL and ZPSV, PANDROL supplied the sleeper factory with a cam-lock-type FE shoulder holding mechanism. This required the conversion of the existing Vossloh moulds to PANDROL FE.

30 sleeper moulds were converted in total, with each mould incorporating five sleeper cells. Throughout this process, PANDROL were in attendance to ensure the sleeper accuracy and quality was maintained. All the necessary inspection gauges were designed and supplied by PANDROL.

The finished sleepers were transported by rail from ZPSV, and built into panels at Anton station. The running rails of a redundant secondary line were used as a level bed for alignment of the sleepers. Panel building is the preferred method for track installation in many eastern European countries. The panels were assembled in lengths of 36 m, with a sleeper spacing of 0.58 m on tight curves. There were either 58 or 62 sleepers per panel depending on the curve radius. Each panel was then stored to a maximum stack height of nine sleepers.

During the same time period, the track bed was being prepared.

The panels were transferred onto flat-bed wagons behind a stationary locomotive on existing track. For building the track, a Geismar Track Panel Laying machine was used to lay the panels sequentially. This is a three-stage process: Panel Lifting, Panel Transporting and Panel Laying. This machine was used effectively to lay all 175 pre-assembled panels.

During the panel building stage, PANDROL loaned the project two Rosenqvist CD200 clip driving machines. This is a walk-behind machine capable of clipping, extracting and sleeper lifting. The machines enabled each panel to be 'clipped-up' in 10 minutes. Training in use of the machines was provided by Rosenqvist engineers, together with handtool training by PANDROL engineers. After seeing the Rosenqvist CD200 machines in action, the Bulgarian contractor, TRACE, ordered two additional machines for their own inventory.

The installation was undertaken by TRACE. The track build began in July 2014 and was completed by September 2014. The de-stress was undertaken in March 2015, when the rail temperatures were stabilized.



Panel Lifter



Motorised Shuttle



Panel Layer



Panel Transporter Shuttle and Panel Layer



Panel Transporter Shuttle and Panel Layer



Panel Transporter Shuttle and Panel Layer



Panel Transporter Shuttle



Panel Transporter Shuttle

All the panels were temporarily connected with joint bars, then flash butt welded. During the welding process, approximately 50 mm of rail is consumed. The rail is mainly absorbed from the loose rail in front of the welding unit train.

Ballast was then dropped and was followed up by a Ballast tamping machine. Several passes by the tamper were undertaken to achieve correct line and level.

The track was open to traffic in early October, although a speed reduction remained in place until the rail stressing operation had been carried out. Due to extreme weather conditions, the de-stress could not be carried out until March 2015.

A quantity of new-design, adjustable 300 FeVSR were also supplied and trialled by Vortok. The new design is adjustable and is capable of working on gauge-widening assemblies. The contractors were impressed with the ease and speed with which the de-stress operation was carried out. The trial allowed Vortok to make future improvements to the design.

Following the successful de-stress, the track was opened to traffic without speed restrictions and has been performing successfully since.



Flash Butt Welder



Ballast Tamping in Progress

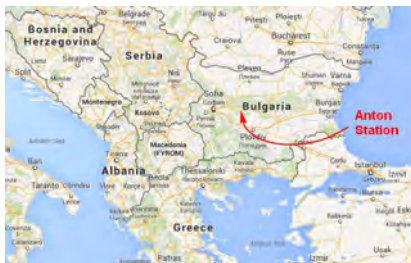

Map Data ©2016 Google



Refurbishing River Stour Bridge, Dorset



The River Stour Bridge, near Christchurch station in Dorset, is a steel structure with timber sleepers.

When contractors Geoffrey Osborne and Sonic Rail began a project to reduce the bridge's maintenance liability and improve track alignment, they chose to replace the timber with longitudinal steel beams fitted with PANDROL VIPA-SP baseplates.

The benefits of VIPA-SP included a reduction in secondary radiated noise from the bridge.

The London-Bournemouth route is electrified using the third rail conductor system. This type of DC electrification has an intrinsic risk of corrosion from earth leakage currents, and requires considerably more insulation within the rail fastenings and between the rails and the structure. The additional need for guard rails over the bridge, compounds the complexity of the track. PANDROL assisted with the design process from the beginning. PANDROL supported the project through fit and function assembly trials at the steelwork fabricator, on-site training, and installation advice.



VIPA-SP assembly trial at the steelwork fabricator, McNealy Brown



Steel beams delivered to the work site complete with VIPA-SP



PANDROL training session at Christchurch



Google Earth view of the River Stour Bridge

Imagery ©2016 Google, Map Data ©2016 Google



Christchurch in Dorset

'Track atlas of Mainland Britain' published by Platform 5 Publishing Ltd



Google Earth view of Christchurch with River Stour on the left

Imagery ©2016 Google, Map Data ©2016 Google



Transition and guard rail assembly on the approach side of the bridge



End of the steel beams with VIPA-SP at the abutments into the transition



Down-line during track inspection in January 2016



River Stour bridge covered in scaffolding to shield neighbours from spray

Following a track contractor briefing session, the work was carried out during a Christmas blockade in 2015.

The down line on the bridge was completed during the blockade, and refurbishment of the steel structure continued in subsequent weekend possessions. Structural improvements included complete cleaning and repainting of the structure to improve corrosion protection. The PANDROL VIPA-SP clips featured a Sherardised finish, which protects against tidal salt water river conditions. Vortok clip-on insulators were fitted to the foot of the rail between each VIPA-SP baseplate, to reduce earth leakage currents and protect the structure from accelerated corrosion.



VIPA-SP adjacent to Guard Rail baseplate



Anchorage detail and height adjusting shim

Refurbishing River Avon Bridge, Dorset

The curvature and cant of the track are clearly visible from the over-bridge at Fairmile Road

The River Avon Bridge near Christchurch, Dorset provides one of only two train routes into the major British seaside town of Bournemouth. The bridge is a multi-span steel structure, which lies on a tight curve with large track cant to provide line-speed of up to 70 mph. Vibration and noise are issues in this environmentally sensitive location.



Contractors Geoffrey Osborne and Sonic Rail chose PANDROL VIPA-SP to reduce the vibration, due to its practical installation method and suitability for steel structures.



The multi-span steel structure viewed from the banks of the River Avon



The cant plate and spherical washers

A key challenge of the project was the need to achieve a changing track cant across the structure, due to the transition in the curve. The solution involved welding 'cant plates' to the upper flange of the steel beams. This achieved the correct cant angle for each rail seat position, ensuring that the baseplates were coplanar with those on the opposite rail. Variations in the vertical height were achieved using shims. The anchorage had to be drilled perpendicular to the cant angle, requiring use of spherical washers on the underside of the top flange of the longitudinal beam.

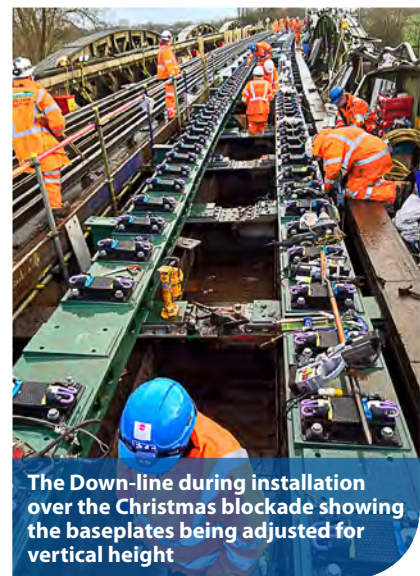

The Down-line during installation over the Christmas blockade showing the baseplates being adjusted for vertical height



Christchurch station



Track and bridge during the inspection in January 2016

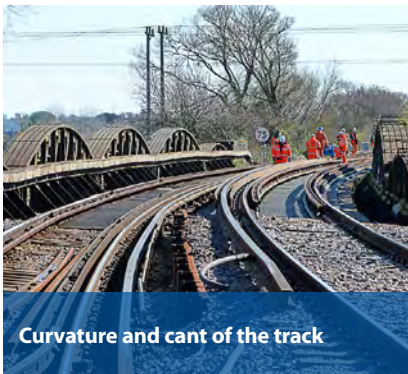

Curvature and cant of the track

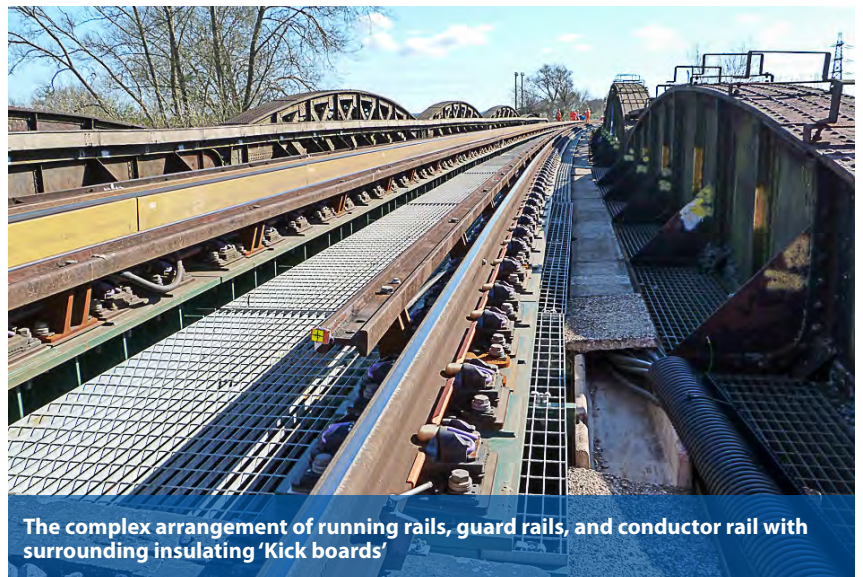

The complex arrangement of running rails, guard rails, and conductor rail with surrounding insulating 'Kick boards'



Assembly trial at '4-Tees'



The underside of the top flange showing the spherical washers. The cant plates and the position of the conductor rail are also clearly visible.

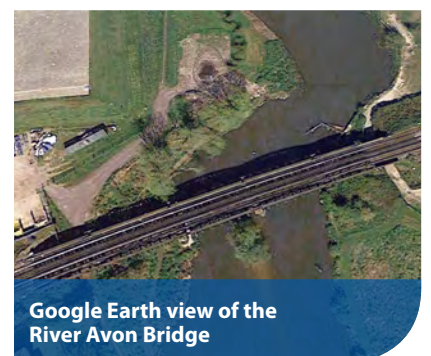

Google Earth view of the River Avon Bridge

Imagery ©2016 Google, Map Data ©2016 Google

The cant plate on the upper surface and the spherical washers on the top flange are clearly visible in these photos. Because of the project's complexity a fit and function test was first carried out by steel fabrication company Four Tees Engineers, using the insulator pots and the guard rail brackets as part of the assembly.

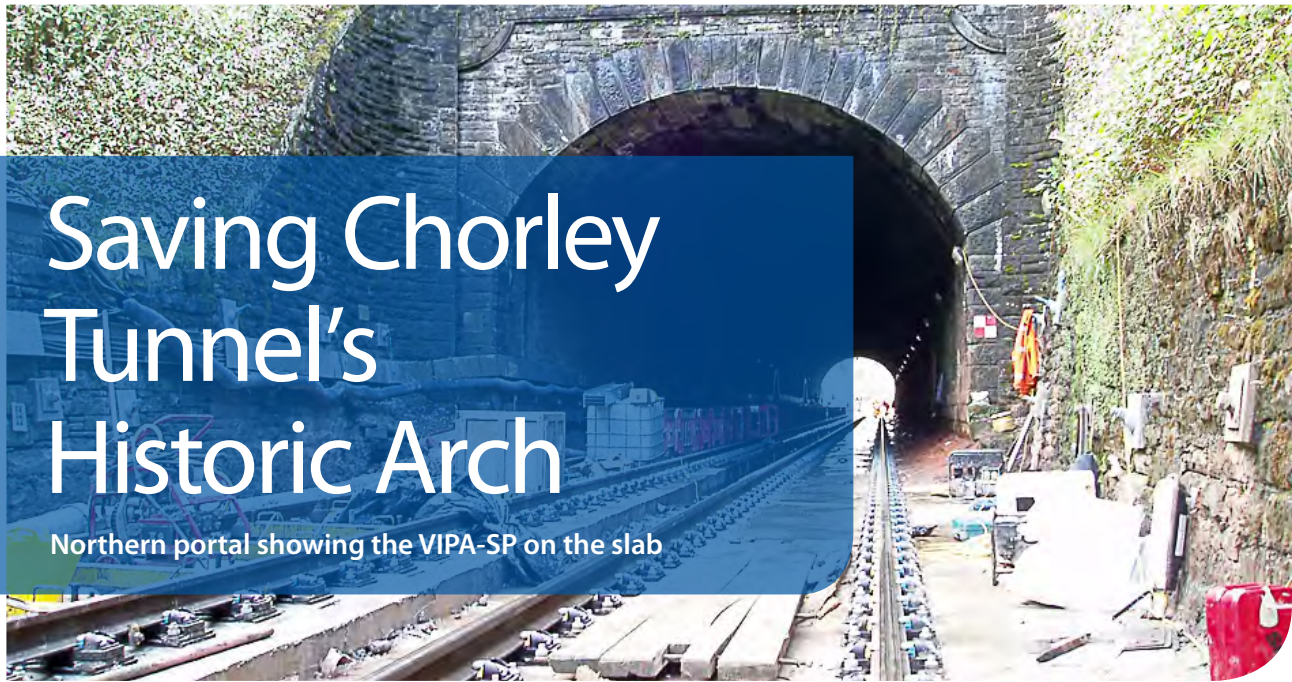

Saving Chorley Tunnel's Historic Arch

Northern portal showing the VIPA-SP on the slab

With the Manchester-Preston route scheduled for electrification during Network Rails control period 5, preparations were needed to make sure the new overhead lines (OHL) equipment would fit in the route's three tunnels. Investigation showed Chorley Tunnel's track would need to be lowered to accommodate the new overhead catenary wires. Yet given that the tunnel's masonry arch was built in 1843 from local sandstone, all involved were keen to preserve it.

The ballast track needed to be lowered by over 0.6 metres, which threatened support for the historic masonry arch.

The contractor, Murphy Group, opted to install a modular, prefabricated track slab, to reduce the risk of collapse between the excavation of the tunnel floor and the installation of the slab. The slabs were supported by the PANDROL VIPA SP which

is a resilient track support system. It was an ideal solution: the new slabs would support the original masonry arch after the sandstone of the tunnel floor was removed by the excavation, while maintaining good track alignment.

The purpose-designed slab panels also featured a cantilever key, to provide support across the 6-foot central drainage channel.

The slabs were precast in Ireland by Shay Murtagh and delivered to site with plastic inserts, for easy screwing of the VIPA SP baseplates to the upper surface before the panels were craned into location. The track installation was undertaken by Stobart Rail. These photographs show the project nearing completion in August 2014.

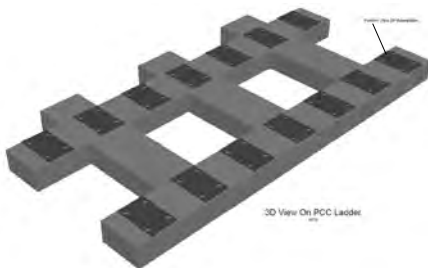

Modular precast 'ladder' panel to reduce mass

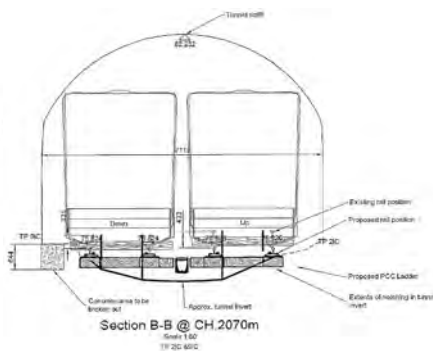

Section through the tunnel at the midway point



Transition between ballast and slab at the Southern portal



Inserting the clips with hand-tools



The southern portal



Ballast track: G44 concrete sleepers under the refurbished 'Flying Arches'



VIPA-SP with anchor screws into inserts



Completed track on the down line looking northwards

Globe-trotting CD400SP Clip Driver ready for UK



The Rosenqvist Rail Clip Driver CD400SP is a walk-behind machine for clipping and unclipping PANDROL clips. The CD400SP is easily configured to handle a range of products including PANDROL FASTCLIP, PANDROL e-CLIPs and PANDROL PR-CLIPs (PR400 series).

The CD400SP is easily configured to handle a range of products including PANDROL FASTCLIP, PANDROL e-CLIPs and PANDROL PR-clips (PR400 series). CD400SP is self-propelled with a reliable diesel engine, and easy for a single operator to operate via a control panel.

From the handheld control panel, the operator controls the functions of the CD400SP e.g. speed, clipping and declipping. The CD400SP has an automatic system, using inductive sensors to identify the next sleepers and automatically trigger the clipping operation. The capacity is up to 30 sleepers/minute for FASTCLIP and 10 sleepers per minute for e-CLIPs. The CD400SP replaces the old PANDROL MarkIV machines, which are now becoming obsolete.

The Clip Driver CD400SP has already been used for a number of years around the globe, from Brazil to South Africa and the USA. Now it's also available in the UK, after receiving its Network Rail product acceptance certificate in December last year. The machine has been redesigned in several areas to meet the British RIS1530 requirements and has been equipped with

fixed covers for moving parts, 'Life guards' on the rail wheels, a 4-wheel brake system, load holding valves on the hydraulic cylinders and an electrical recovery system. The control system has been upgraded with respect to safety and reliability and now complies to Performance Level c (PLc). The first eight UK machines are now owned and operated by Speedy Services.

The CD400SP was also a winner at the Rail Live Awards held in June 2016 in the UK, where the machine was awarded the best small plant innovation. The prize was given to Speedy Services for introducing it to the UK market.



Speedy team at Rail Live

Top row from left: Adam Mann (Speedy), Danny (Speedy), Erika Berg (Rosenqvist), Colin Wight (Speedy), Dave Creasey (Speedy), Louise Hession (Speedy)
Bottom row from left: Mats Nilsson (Rosenqvist), Bjorn Soderberg (Rosenqvist), Derrick Howe (Speedy)

Plastic Baseplate assemblies for Urban Transit Systems

Author: Philippe Matuch

PANDROL Track Systems' decade of experience in the field of high-performance plastic baseplates is a combination of a strong, permanent Research & Development program and a large installed base in urban slab-tracks.

This unique experience is based on the successful implementation of Nabla Tram baseplates, which have been developed as an optimised rail fastening solution for tram networks. Suitable for top-down standard installation, and also mechanized installation in the fresh concrete, Nabla Tram baseplates have demonstrated their quality and effectiveness many times, since their first installation, in Reims and Orléans (France).

After these initial developments, the product range of urban plastic baseplates has been continuously enlarged. It now includes the products SEE-SD and DEE-SD, respectively designed for a typical vertical dynamic stiffness of around 60 kN/mm and 30 kN/mm.

References & expertise of nearly half a million of fastening systems

Approximately 250,000 fastening systems with Nabla Tram plastic baseplates have been sold and installed on networks in Reims, Orléans, Paris RATP, Brest, Le Havre, Lyon, Nice, Besancon, Toulouse, Bordeaux (France); Nottingham (UK), Casablanca (Morocco), Sidi-Bel-Abbes (Algeria), and Kaohsiung (Taiwan). In addition, more than 5,000 fastening systems with DEE-SD plastic baseplates have been installed on the Nottingham NET2 line (UK). Last but not least, more than 200,000 fastening systems with SEE-SD plastic baseplates are now being delivered to Santiago Metro Lines 3 and 6 (Chili).

Proven thanks to years of commercial service on track with similar systems, and approved thanks to the homologation tests, including tests performed by the independent laboratories, our standard SEE-SD and DEE-SD fasteners maximize the

use of common components. For instance, they share the same anchorage solution, in order to facilitate installation work and future maintenance operations.



Nabla-Tram baseplates

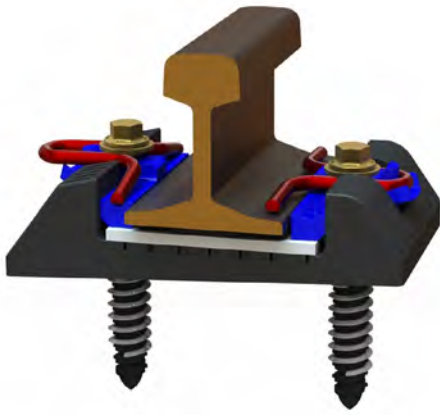

SEE-SD E364068c

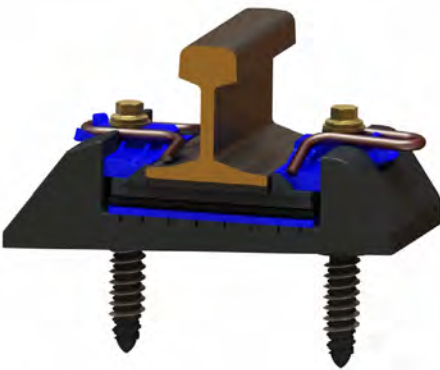

DEE-SD E364069a

Baseplate design

The SEE-SD and DEE-SD system baseplates are made of glass fibre-reinforced polyamide material, in order to provide maximum strength under lateral loads. The baseplates of both systems also include special features, with vents and systems of channels to guarantee optimal insertion in the concrete. The vents and channels are essential to ensure that the baseplate is correctly embedded in the fresh concrete. The fact that the baseplate is 'locked' in the concrete ensures excellent resistance to lateral forces. Tightening to refusal, as used on the insulated-blocks and the SD clips, contributes greatly to this locking. The baseplate is not 'laid' on the concrete but 'anchored' and integrated into the concrete. There is consequently no risk of sliding.

In addition, the stress level in the screws is significantly reduced. Consequently, the anchorage system is able to use only two screws, even on tight curves.

SEE-SD & DEE-SD standard fasteners

In terms of performance and technical validation, SEE-SD and DEE-SD have successfully met all the requirements of the latest issues of EN 13146 and EN 13481-5. In addition, their performance related to electrical insulation meet the EN 13146-5:2012 standard. The level of insulation is at least 30 kΩ between two rail-seats.

A wide range of pad stiffness is available for these systems, depending on traffic conditions, track design, and noise and vibration mitigation requirements. They are compliant with the NF F 50-025 and UIC 864-5-O standards, and they are specially designed to meet various stiffness requirements.

SD clips & insulated blocks

Both SEE-SD and DEE-SD use the SD clip solution, which was developed by PANDROL Track Systems in order to offer a screwed solution that optimises track construction costs and offers very high technical performance. SD means 'Safely Driven', referring to the controlled clip guidance from the parked to the in-service position. Tightening to refusal is the standard method used on SD systems. Together with this feature, the high elasticity of the SD clip ensures a regular clamping force and a constant longitudinal restraint. SD clips are manufactured using spring-quality silico-manganese steel, with standard rod diameter of 13 mm. The static deflection of the clip when tightening is greater than 10 mm, which leads to a toe load of 9 kN per clip, i.e. 18 kN per rail-seat.

In the case of the SD2 clips used on DEE-SD systems, it is possible to reach a dynamic deflection of approximately 2 mm. This is thanks to their shape, which was specially designed to work under torsion.

The insulated block is the key component in the interface between the baseplate and the other components.

Mechanical, electrical and functional features of the fastening system, as well as its level of performance, are all directly linked to the design principles of the insulated-blocks. SD insulated blocks are designed using a deep-post insulator, in order to maintain the consistency of the track-gauge. This special design, combined with the use of glass-fibre-reinforced polyamide material, improves the behaviour of this component under lateral loads.

The major innovation brought by SD fastening systems is based on the special design of the insulated-blocks: it ensures an optimised guiding of the clip from its parked-position to the in-service-position. The shape of the insulated-block has been specifically developed to guarantee an excellent clip translation movement. It also reduces the risk of unreliable clip position during the installation phase.

SD insulated blocks are designed to offer lateral adjustment of the track-gauge in steps of 1.25 mm. The method to adjust the gauge is very simple: change the insulated-block combination. Vertical adjustment is achieved through plastic shims, enabling level correction up to 30 mm.

Conclusion

Completely proven by years of commercial service, as well as being approved by laboratory validation tests, the state-of-the-art plastic baseplates proposed by PANDROL Track Systems – Nabla Tram, SEE-SD and DEE-SD – meet the requirements for all urban rail-networks, from tram lines to LRT and high-capacity metro applications.

Focus on Santiago Metro, Chile

PTS is responsible for the delivery to a consortium of French rail infrastructure construction and maintenance companies of more than 200,000 SEE-SD fastening systems for Santiago Metro (Chile). This award is a part of a 20-year contract for construction and maintenance of the new Santiago metro lines 3 and 6. Track-works started late 2015.

Connecting two holy cities



PANDROL CDM Track, a key member of the PANDROL family, recently won a major contract to supply track for the Haramain High Speed Rail Project in Saudi Arabia. PANDROL CDM Track will supply its innovative CDM-QTrack system to the project.



Haramain is an important railway route in Saudi Arabia. Its name translates as 'the two holy cities', meaning the link between the cities of Makkah and Madinah. The route also passes through Jeddah, the biggest city on Saudi Arabia's west coast.

CDM-QTrack was chosen for its ability to eliminate difficult tamping and maintenance operations in rail stations. Stakeholders of the Haramain High Speed Rail Project also recognised the advantages CDM-QTrack in terms of speed of installation, resistance to harsh climatic conditions, and full compliance with EN standards.

The contract covers 17km of track, including the stations at Madinah, Makkah, KAEC (King Abdullah), KAIA (King Abdul-Aziz International Airport), and Jeddah. The start date for the contract was the fourth quarter of 2015.

VANGUARD Retrofit

Solves noise problem for London Underground

Track installation completed with tunnel portal in distance

It's getting harder for railways to ignore complaints about noise. Thankfully, with support from PANDROL, the London Underground is working to reduce noise in innovative ways. Until recently it was possible for operators to dismiss most complaints on the grounds that the railways have the prior use of most sites, but neighbours of railways and the general public are becoming more vocal in their opposition to noise.

London Underground faces this challenge on many fronts, especially where the use of neighbouring and adjoining buildings has changed. Change of use can result in the sensitivity to noise and vibration being increased. This is especially obvious when commercial buildings are altered to become apartments, or when a building is converted into a place of worship. With London Underground also planning to extend its operating hours throughout the night, noise problems for nearby residents may be about to get even worse.

London Underground recognised this trend many years ago and has now embarked on a joint development project with PANDROL to retrofit its deep tube tracks. The goal is to add resilience to existing embedded sleepers, without the

need to break out and excavate the slab track. That means local people will hear less rail noise.

The deep tubes on the London Underground form the central core of the network. They have been gradually renewed over the last 30 years, to replace the original bull-head rail on timber sleepers with a modern, concrete sleeper capable of supporting standard flat-bottom rail. The small concrete sleeper type NTF415 has been embedded in mass concrete to create slab track over most of the deep tube routes. This sleeper was designed for a PANDROL 'e' clip assembly, capable of providing the adjustment needed for most slab track installations. The PANDROL assembly achieved the adjustment using shoulders cast into each

concrete sleeper. The PANDROL shoulders are higher, to provide vertical adjustment, and have a wider rail seat, to provide lateral adjustment. This wider rail seat and taller shoulders have provided the opportunity to retrofit a special variant of the PANDROL VANGUARD system.

The original 'e' clip assembly was relatively stiff and was designed at a time when vibration attenuation was not a major requirement. In order to attenuate vibration without changing the whole track, it is necessary to substantially soften the rail fastening assembly to effectively cushion the structure of the tunnels from the track. Ground-borne vibration is then diminished into adjacent structures and adjoining properties.

The joint development project comprised three main phases:

1. Development and testing of the retrofit assembly
2. In-track trials for both 'build-ability' and vibration attenuation tests
3. Training and pilot installations

PANDROL VANGUARD has been used for many years. The first London Underground installation was on the Victoria Line in 1999, and VANGUARD has also been installed at many other locations around the world. Most previous installations were new projects using various forms of baseplate, but there had been two previous examples of retrofitting VANGUARD in Singapore and China. The PANDROL team's experience in amending VANGUARD to fit existing track parameters proved extremely useful in the London Underground project.

Having designed the new components, and produced prototype samples for laboratory testing, a series of installation tests were conducted at Shepherd's Bush. The tests found that a significant number of the sleepers were set in a 'skewed' condition in the mass concrete. A small design revision was necessary in order to install the VANGUARD in the majority of sleepers, including sleepers skewed up to a maximum amount. Further installation trials were then undertaken, most of which returned the track to the original form prior to trains running.

Moving into the second phase, installations were conducted to leave the new assembly in-track. This allowed the team to measure noise and vibration attenuation, before and after installation. The results supported other data from London Underground and sites around the world. The VANGUARD assembly reduced the amount of vibration in the neighbouring building to below the level of background noise, making it impossible to hear the trains in neighbouring basements. The test measurements were dramatic and can be seen in the graph right.

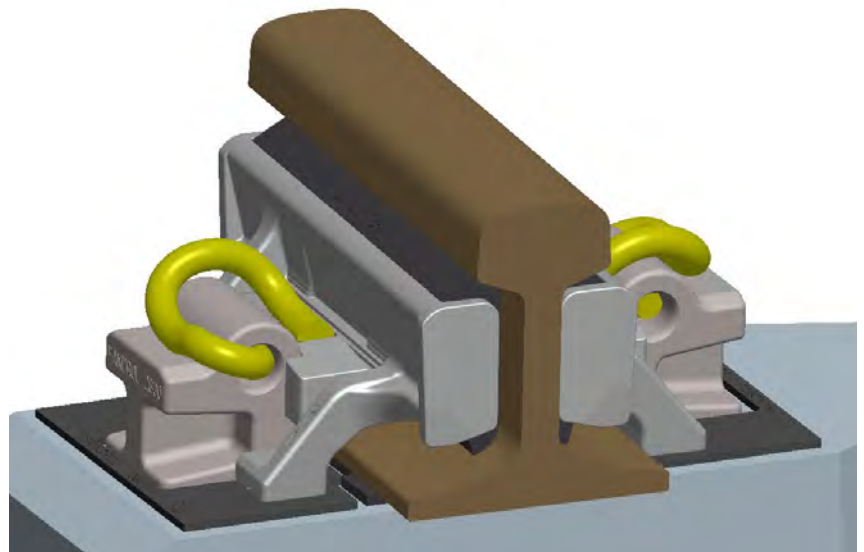

The 'e' clip rail seat on NTF415 sleepers with the VANGUARD retrofit on the same rail seat

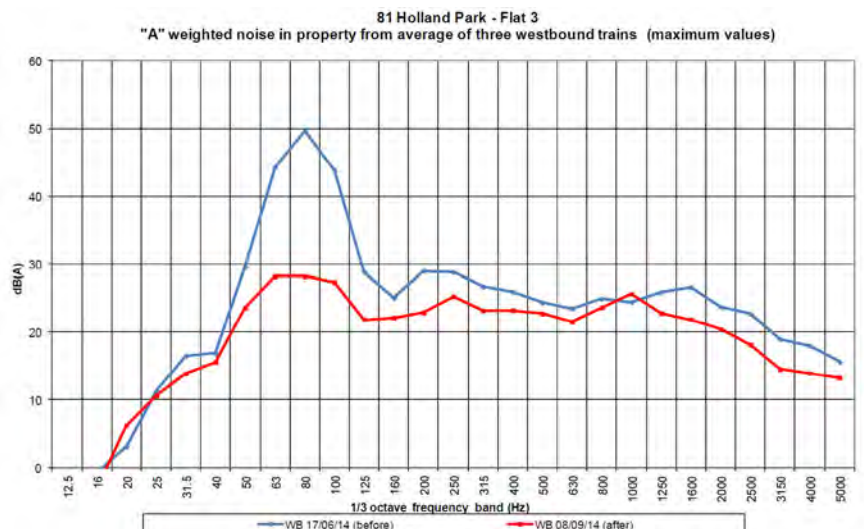

The London Underground report concluded:

- In-property noise from trains on the trial site have been reduced from 48dB(A) to 32dB(A) and all impulsive boom has disappeared. Westbound trains are now barely audible.

- Levels of ground-borne vibration have been reduced from 12 mm/s² to 3 mm/s²

- Frequency analysis shows a significant reduction in the 63 to 100 Hz one-third octave band



The first trial at Shepherds Bush



Pilot installation at Maida Vale



Holland Park installation



Hydraulic tool compresses the rubber components

PANDROL and London Underground moved into the final phase of the development by commencing training of the installation teams. Pilot installations at Holland Park and Maida Vale have been successfully concluded. The installation teams have achieved very good yardage of conversion, because no break out of the concrete is needed and the rails only need to be unclipped.

The project has now moved to the first major track conversions under normal commercial terms, and the development has helped London Underground to quieten the railway for neighbours. Underground services can now be extended throughout the night, without disturbing residents.

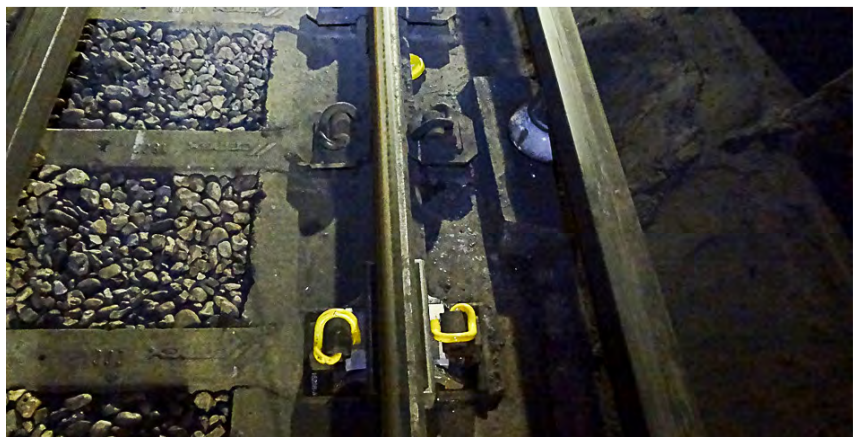

Transition between rail fastenings: VANGUARD to 'e' clip

Quietestening The Golden Horn Metro Bridge



Following a tender by Istanbul Metropolitan Municipality, the Golden Horn Metro Bridge was completed in February 2014. Key to its success was the selection of the PANDROL VANGUARD rail fastening system for the critical areas, namely around the historical structures and the Genoese Walls, due to its impressive sound and vibration suppression characteristics.

The bridge connects the two sides of Golden Horn as part of the M2 Istanbul Subway line, on the European side of Istanbul. The bridge is also located in a historical district of Istanbul. Its structure consists of concrete viaducts at each end, providing access to the tunnels with a metal suspension bridge between them. Besides their structural purposes, the bridge's abutments were also designed to symbolize the horn-shaped appearance of the Haliç Peninsula. At the tunnel entrances, the subway line goes under the historic Genoese city walls, over the Ottoman bathhouse, and under the historic Ottoman building and houses.

One of the most challenging aspects of the project, and thus one of the most significant successes of it, was to build the subway line without damaging the historical character of the oldest district of Istanbul – the history of which goes back

thousands of years – and the artefacts therein. The project even aimed to exhibit newly-found relics along with the already-known ones at the construction site, and the known history of Istanbul changed following new finds at the excavation site. More than 50,000 artefacts have been dug out, along with numerous antique ships made from wood. These have proved that Istanbul's history extends back 8,500 years ago.

Due to the historic fabric of the district, certain measures were adopted during the planning and execution of the project. The historic buildings and the Genoese Walls on the Şişhane-Yenikapı railway route were dismantled on site and carried to other locations. Wherever possible, protection of the historical structures on their original sites and construction of the railway route underneath them were also sought, following the decision of

the Monument Protection Board of the Republic of Turkey.

The Golden Horn Metro Bridge is a swing bridge that can rotate horizontally to allow ships through. The bridge is at a height of 13 meters above sea level and has a length of 460 meters. When including the viaducts on each side, the total length adds up to 936 meters. It has five abutments.



The bridge carries a two-lane railway. The contractor firm, Alsim Alarko A.Ş., conducted specific railway design studies for this project in order to comply with the vibration and sound regulations.

The curve on the surface of the steel bridge, which is necessary for drainage purposes, and the gaps between the fastenings and the steel surface, posed a significant challenge. This was eventually solved through use of steel platforms with adjustable height, which were specifically designed for this project.



The steel platforms are fixed through welding on the surface of the steel bridge. On the concrete viaduct, on the other hand, the fastenings are fixed via plinths with anchor bolts.

The rubber wedges integrated in the Vanguard system, which keep the rail

suspended above the bridge surface, provide great flexibility: they add immensely to the electrical isolation, as well as to the vibration and sound suppression. The fastenings are placed with a 65 cm gap between each other (on average).

The Golden Horn Metro Bridge has been in use since its opening in February 2014. It has proven itself as an efficient contribution to the public transport solutions offered by the municipality, as well as an aesthetic added-value to the skyline of Haliç district.

The Klang Valley MRT Line 1: Sungai Buloh to Kajang



Phase 1 of the 3 Line MRT system is the Sungai Buloh to Kajang Line. Running roughly North West to South East across Kuala Lumpur, it forms the first part of the capital's new integrated transport system. It comprises 51 route kilometres of metro track and two brand new depots.

Starting in the North West at Sungai Buloh the line heads south east running through the heart of KL. It will serve a corridor with an estimated population of 1.2 million people.

When finished it is expected to have a daily ridership of approximately 400,000 passengers travelling on 4 car driverless trains each with a capacity of 1200.

Train headways will be at 3.5 minute intervals and the line is expected to be fully completed and operational by the July 2017.

When fully completed the three new lines of KVMRT will comprise more than 140 km of metro.

The alignment of Line 1 is mostly elevated on viaduct, although for 9.5 km it will pass

underground through the busy city centre. There will be 31 new stations altogether with 7 of them being underground.

PANDROL Track Systems are supplying all the rail fastenings for the entire line and depots. The Third rail power electrification system is also being supplied by PANDROL.



Fasteners

PANDROL Track Systems are supplying approximately 320,000 VIPA DRS fasteners for Line 1.

This system is well proven in many metro projects worldwide. It offers low vertical stiffness and is ideally suited to applications where this level of track support resilience is required. It combines the proven technology of the PANDROL e-CLIP in a baseplated system that offers adjustment and is easy to maintain.

The areas of track that are subject to high vibration sensitivity require special treatment. These are areas predominantly in the underground sections of track where the metro passes close to sensitive receivers such as domestic dwellings, offices and other locations where re-radiated noise must be minimised.

For those sections of track the PANDROL VANGUARD baseplate fastener will be used. Nearly 40,000 VANGUARD baseplates will be installed in total. As this is the first time this product has been used in Malaysia, PANDROL have been giving on-site demonstrations on how to install and maintain this fastener.

In addition to providing protection from harmful vibration, the VANGUARD fastener has another trick up its sleeve. A version has been designed which will retrofit onto the VIPA-DRS baseplate without disturbing the rail position or inclination. This means that in the future, if areas of the metro route become developed meaning the track requires upgrading to provide more protection, this can be done speedily, easily and economically.

In addition to the mainline fasteners mentioned above, PANDROL is also supplying fasteners for 37,000 concrete sleepers in the two depots, nearly 5,000 check rail assemblies and other fasteners for depot wash plants and inspection pits etc.

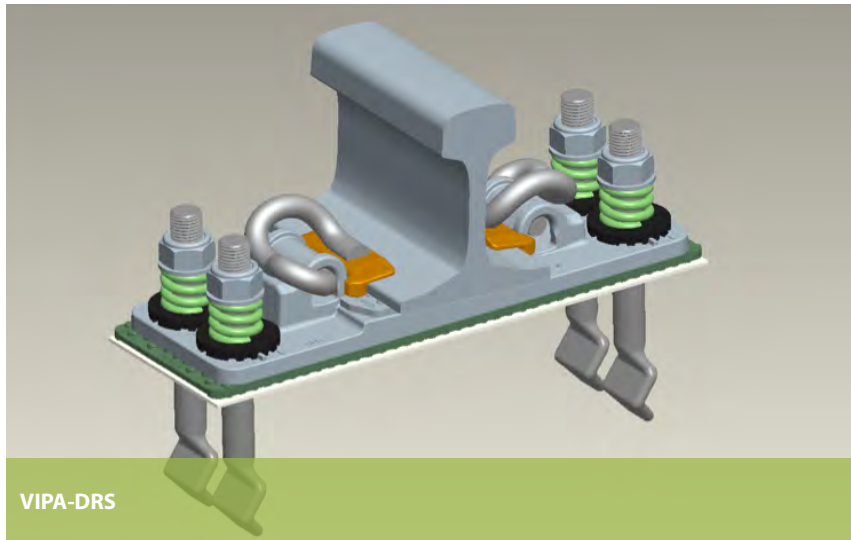

VIPA-DRS



VANGUARD training school

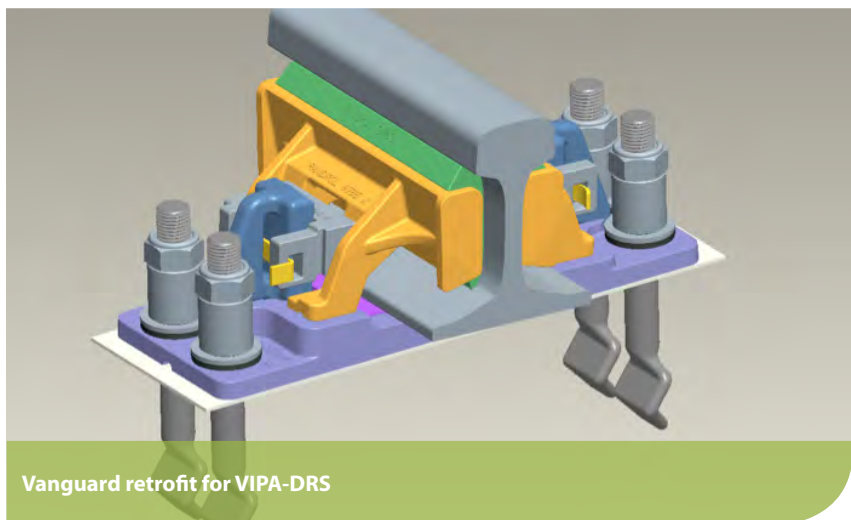

Vanguard retrofit for VIPA-DRS



Mainline track on viaduct near Sungai Buloh



Mainline sleepers being prepared

PANDROL VIPA DRS technology for Ui Metro in Seoul



The Seoul City metropolitan area in South Korea has a population of more than 20 million. That has unsurprisingly led to major traffic congestion problems, which city planners are keen to solve through light rail – with support from PANDROL Korea and VIPA DRS e-CLIP baseplates.

The Ui Metro or Ui Light Rapid Transit (LRT) project began construction in 2009, in the north-east area of Seoul. Designed to improve accessibility and promote balanced regional development across the city, the Ui Metro project opens in 2016.

The completed Ui Metro will feature:

- 11.4km of track, terminating at Ui-dong station
- 13 stations
- 33.8 km/h scheduled speed
- 80 km/h designed maximum speed
- Rail type KS 50 kg

PANDROL Korea played an important role in the project design, by working alongside designers 'Saman' and 'KRTC' from the initial stages. The project is using direct fixation and top-down construction methods, rather than sleepers, thanks to the introduction of the innovative VIPA DRS baseplates.

It is first Korean installation of VIPA DRS in Korea, and PANDROL Korea supplied around 65,000 assemblies of VIPA DRS from January to July 2015. These photos show the Ui Metro project under construction, including as-built track that is already in place.

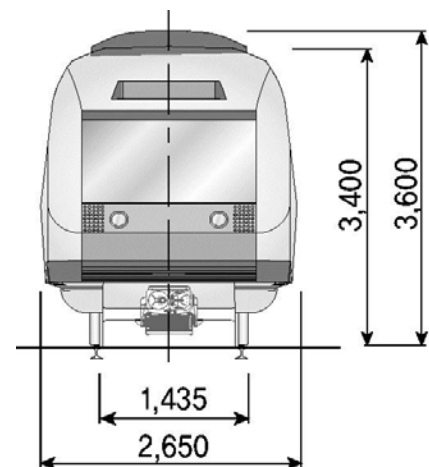



Pre-cast slab ready for rail installation



Clips ready for rail installation



Rail, clip and VIPA-DRS from above

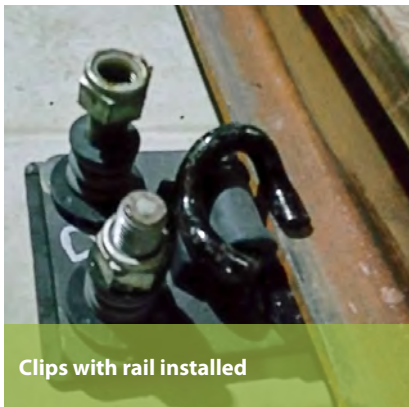

Clips with rail installed



Installed rail track with VIPA-DRS

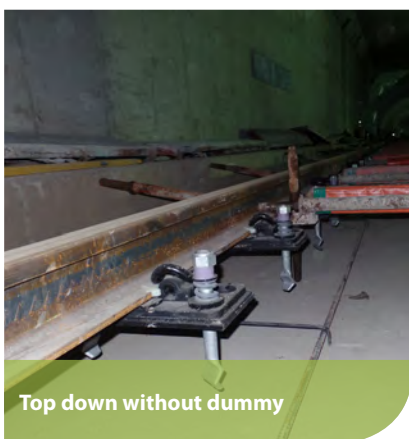

Top down without dummy

New Product Round-up

SD SYSTEM

The PANDROL Safe Driven (SD) fastening system is a pre-assembled, economical yet high performance screwed fastening solution for all categories of track.

SD means 'Safely Driven', referring to the controlled clip guidance from the parked to the in-service position. In addition to its ability for pre-assembly in the concrete sleeper, SD systems have also been designed in order to offer high rates of installation by mechanical methods.

The screws are tightened to refusal which generate the clamping force and longitudinal restraint.

- Multi-purpose fasteners, suitable for various types of concrete sleepers, both for new installation on specific sleeper design and retrofitting on existing sleepers

- Solution specially designed for easy installation: pre-assembly in sleeper plant, compatibility to mechanised/automatic track equipment

SD fasteners have been developed for a wide combination of support types and construction methodologies eg. new concrete sleepers, retrofitting existing concrete sleepers (including SKL), installation on plastic baseplates, dual gauge applications and plastic baseplates for slab tracks.

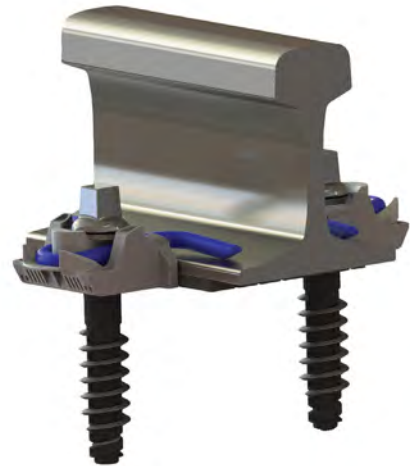

FASTCLIP FCA

PANDROL FASTCLIP FCA is an economical adjustable system for use on slab tracks for Light Rail, Metro, Main Line and High Speed track.

PANDROL FASTCLIP FCA can be assembled at the sleeper factory and delivered to site captive/pre-assembled on the pre-cast element for top down construction with embedded pre-cast concrete elements. The system can also be provided with an alternative construction plate to facilitate wet pour top-down construction.

- Optimised for use on pre-cast blocks, sleepers and slabs
- Suitable for top down construction
- Provides for retrofit adjustment

Low clamping force and rail free variants are available to address track-structure interaction issues



Re SYSTEM

The PANDROL Re SYSTEM delivers an assembly with faster installation times and a reduced number of components when compared to a traditional e-CLIP equivalent.

The PANDROL Re SYSTEM adopts two-part insulator technology and integrated insulator/pad manufacture to provide extended life of components and efficiency gains. This can lead to more productive engineering possessions for track refurbishment, such as re-railing, when clips, pads and insulators are normally replaced. With the PANDROL Re SYSTEM, the rail pad is supplied with the side post insulators already attached, reducing time and labour compared with laying out and installing loose insulators on site.

The Re SYSTEM is supplied with toe insulators already in place on the toe of the clip which reduces installation time and the number of loose components on site.

- Suitable for use on concrete and steel sleepers
- Suitable for use on light rail, metro, general main line, high speed and heavy axle loads

The PANDROL Re SYSTEM installs on new or existing PANDROL e-CLIP or PR CLIP concrete sleepers. It can also be installed on steel sleepers, baseplates and turnouts. The system is optimised for installation during rail change operations where the fastenings are replaced, but can also be used on loose sleeper replacement projects.

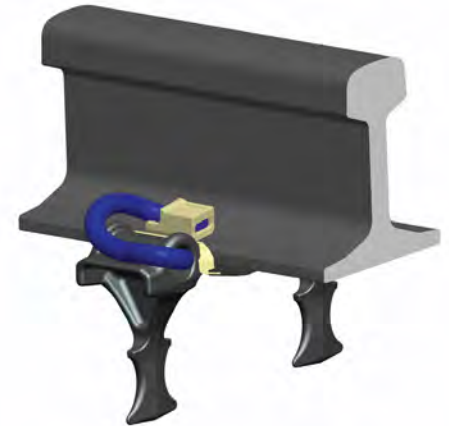

FASTCLIP FE

The PANDROL FASTCLIP FE system is a resilient, threadless, pre-assembled rail fastening system with low installed cost.

PANDROL FASTCLIP has substantial global references and has been designed as a total system in which all components are delivered to site pre-assembled on the sleeper. Once the sleepers are laid, and the rail installed, the clip is simply pushed onto the rail by means of a simple drive action. This switch-on switch-off capability provides the opportunity to mechanise the installation and extraction processes that are on integral parts of track construction and maintenance.

FASTCLIP FE is an economical fastening offering opportunities for installed action savings through the use of high output, mechanised installation equipment.

- Rapid installation capability (up to 70 sleepers per minute)
- FASTCLIP components pre-assembled on sleeper
- Threadless, self tensioned fastening, generates toe load on driving
- Suitable for all track categories



VIPA DFC

The PANDROL VIPA DFC System has been optimised for use in pre-cast blocks, sleepers and slabs. It is an economical, high performance solution for track where some noise and vibration mitigation is required.

PANDROL VIPA DFC has been designed for use on slab tracks where a typical vertical static stiffness of 20-25 kN/mm is required for applications on LRT, Metro, high speed and other non-ballasted tracks. For Heavy Haul applications a stiffer modified version of the system can be supplied.

The PANDROL FASTCLIP fastening allows for efficient stressing and rail maintenance both of which are important when building and operating non-ballasted systems.

- Suitable for use on non-ballasted tracks (slab tracks)
- Optimised for use on pre-cast blocks, sleepers and slabs

- Indirect fastening system with high levels of electrical insulation

PANDROL VIPA DFC baseplates can be delivered to the track site fully pre-assembled on the pre-cast sleeper, block or slab.

The system is an adjustable indirect baseplate type, ideally suited for installation on pre-cast blocks, sleepers or slabs, but can also be installed by wet pour top down methods. Track / structure interaction can be accommodated by low toe load / rail free variants.



NABLA EVOLUTION

The NABLA EVOLUTION Fastening System is an improved version of the original Nabla System that has been proven throughout the world for several decades.

The original NABLA Fastening System has provided safe and reliable tracks in Tram, LRT, Metro, Main Line and High Speed tracks. The special shape of the Nabla blade generates a dynamically stable toe load on the rails when the nut is torqued.

The NABLA EVOLUTION fastening system gives greater performance in tight radius curves, maintains consistent track gauge, increased electrical insulation and improves the overall life expectancy of the assembly components.

- Tightening to refusal providing a constant force on the rail foot
- Lateral adjustment in 1.25 mm increment
- Maintains efficient track gauge control and limits rail movement

The NABLA EVOLUTION Fastening System can be used on concrete sleepers in ballast, tram systems (with or without plastic baseplate) and can also be provided for track structure interface using reduced or zero toe load.







PANDROL VIPA DRS assemblies are installed throughout the Dubai Metro System.