

VIII - LISTE DES PIÈCES DÉTACHÉES

SPARE PARTS LIST

- Version monobloc
Integral unit
- Tête de tranchage
Shearing unit
- Ensemble traverse arrière et partie hydraulique
Back crosspiece suit with hydraulic part
- Circuit hydraulique
Hydraulic fitting

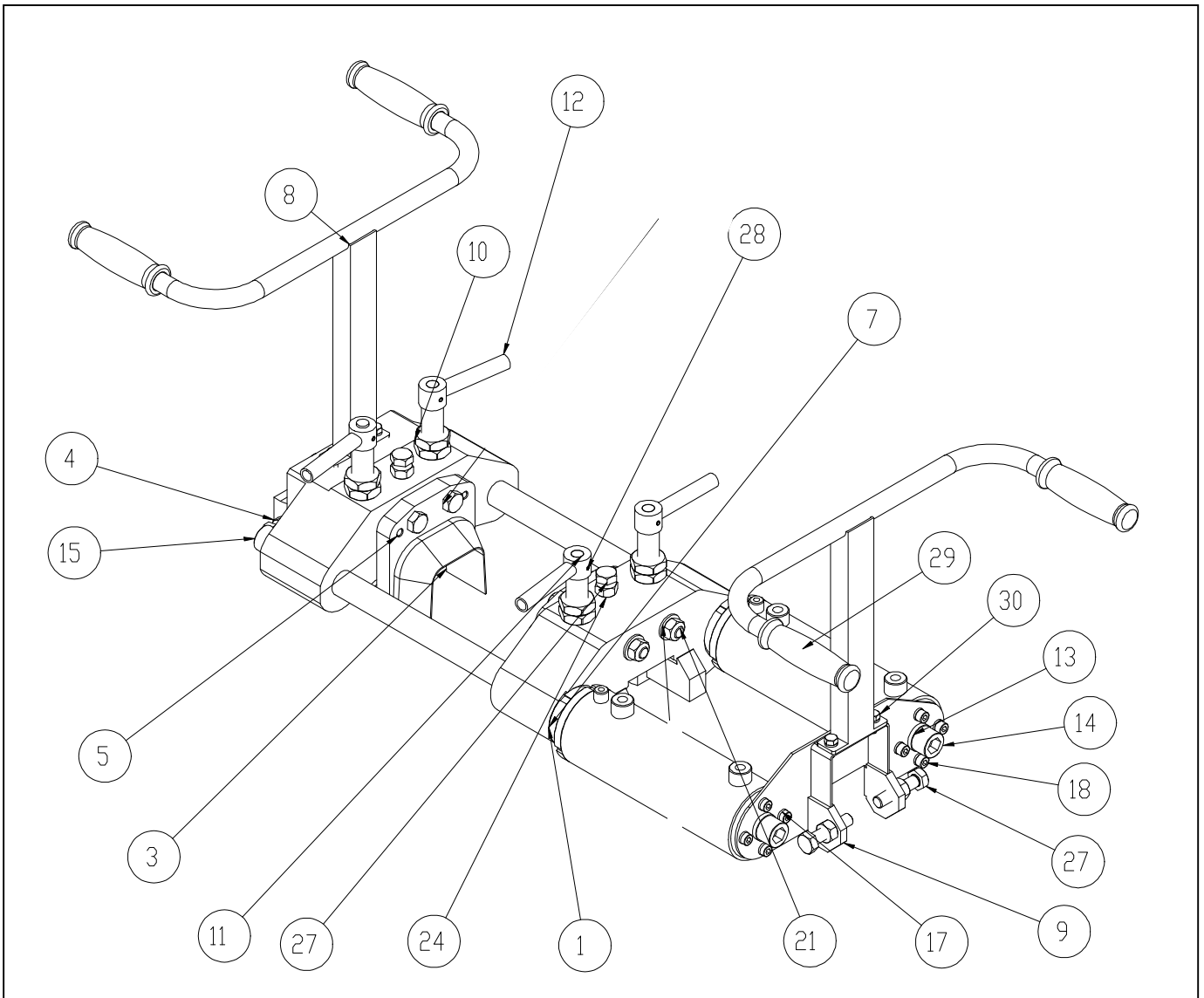

Rep.	Reference	Qté	Désignation	Description
01	32930051	1	Traverse mobile étroite	Narrow moving crosspiece
02			Jeu de couteau (voir liste en annexe)	Blades (refer to the annexed list)
03	32930052	1	Traverse fixe étroite	Narrow fixed crosspiece
04	41304001	4	Pion de centrage Ø 10x30	Centering piece Ø 10x30
05	35910409	2	Poignée de transport	Handle
06	35910408	1	Traverse arrière	Back crosspiece
07	40924001	8	Ecrou Hm M24	Hm M24 nut
08	35910128	4	Crochet à bossage	Hook
09	35910052	4	Poignée de crochet	Hook handle
10	41120002	4	Rondelle W20	Washer W20
11	41020002	2	Vis CHc M20x50	Screw CHc M20x50
12	41020001	2	Vis CHC M20 x 80	CHc M20 x 80 screw
13	41120005	2	Rondelle plate L20 N	L20 N flat washer
14	41108004	12	Rondelle W8	Washer W8
15	41008020	8	Vis HM8 x 20	Screw HM8 x 20
16	41106001	8	Rondelle W6	Washer W6
17	41006012	8	Vis CHC M6 x 90/30	CHc M6 x 90/30 screw
18	40914004	6	Ecrou bas H M14	Nut H M14
19	44201004	2	Joint racleur	Scraper seal
20a	41014002	2	Vis HM14 x 90	HM14 x 90 screw
20b	41014001	4	Vis HM14 x 60	HM14 x 60 screw
21	41301012	4	Goupille élastique 5x30	elastic pin 5x30
22	47401002	4	Poignée caoutchouc	Rubber handle
23	41008033	4	Vis CHc M8 x 20	Screw CHc M8 x 20
24	41016007	2	Vis de butée HM16 x 160	Stop piece screw HM16 x 160
	45301005	4	Bague autolubrifiante	Self lubricating ring
26	47501011	2	Vérin hydraulique allégé	Light hydraulic jack
27	47501003	2	Colonne de vérin	Jack column
	47501016		Pochette de joints de vérin allégé	Gasket kit for light hydraulic jack

ENSEMBLE TRAVERSE ARRIERE ET PARTIE HYDRAULIQUE

BACK CROSSPIECE AND HYDRAULIQUE PART

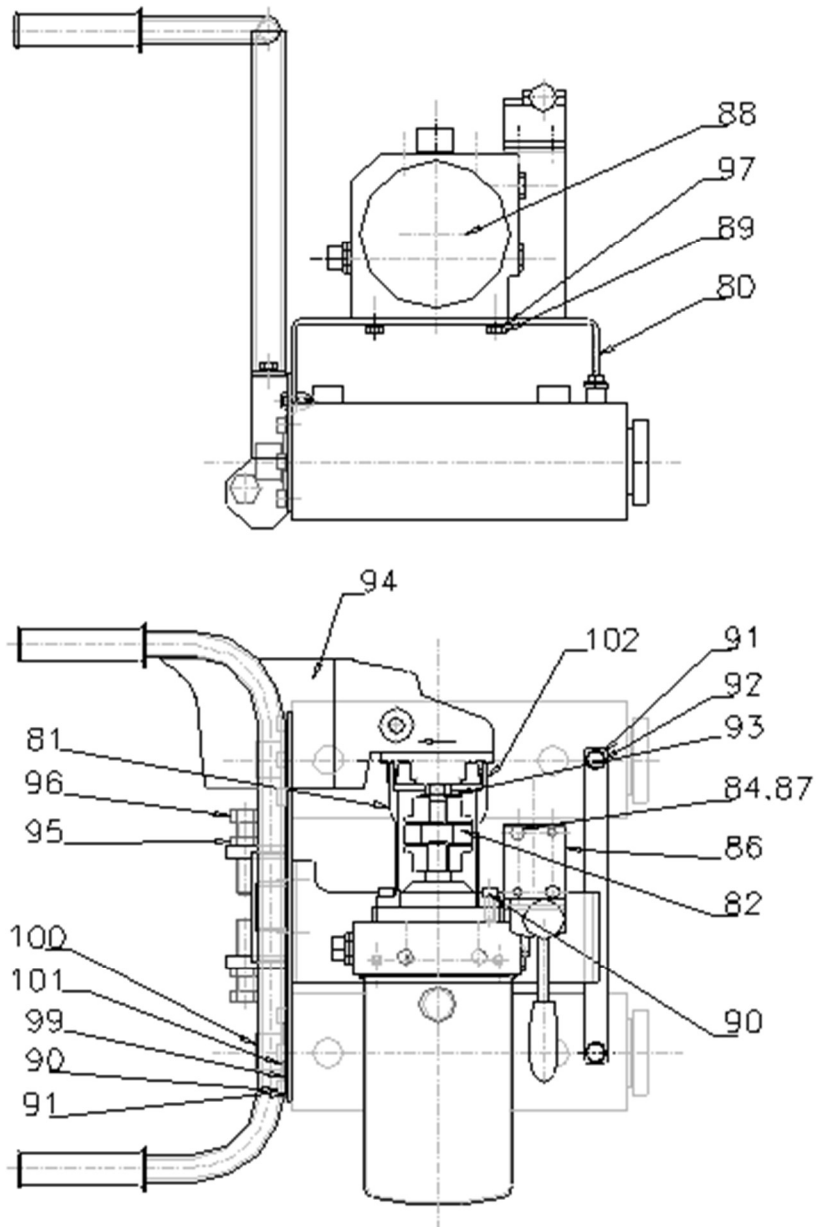

ENSEMBLE TRAVERSE ARRIERE ET PARTIE HYDRAULIQUE
BACK CROSSPIECE AND HYDRAULIQUE PART

Rep./item	Qté.	Référence	Désignation	Description
80	1	34910124	Support de pompe	Pump support
		21334010	Partie hydraulique	Hydraulic part
81	1	31230054	Lanterne	Pinion
82	1	31230028	Accouplement complet	Complete coupling
84	2	40906002	Ecrou HM6	HM6 nut
86	1	47702004	Distributeur	Distributor
87	2	41006024	Vis HM 6x50	HM 6x50 screw
88	1	47103001	Pompe avec réservoir 2l	Pump with tank 2l
89	2	41010002	Vis H M10x20	H M10x20 screw
90	8	41008033	Vis CHc M8 x 20	CHc M8 x 20 screw
91	10	41108004	Rondelle W8	W8 washer
92	2	41006003	Vis HM 8x16	HM 8x16
93	2	41114001	Rondelle M14N	M14N Washer
95	2	40914004	Ecrou Hm M14	Hm M14 nut
96	2	41014003	Vis H M14x 60	H M14x60 screw
97	2	41110002	Rondelle W10	W10 washer
99	2	41120001	Rondelle M20	M20 washer
100	2	41020002	Vis CHc M20 x 50	CHc M20 x 50 screw
101	2	41120002	Rondelle W20	W20 washer
102	1	41601010	Collier de serrage	Hose clamp
103	1	48402025	Moteur Electrique Pandrol	Pandrol electric engine
104	2	48402027	Batterie 18V	Battery 18V
105	1	31210503	Bague d'adapation	Adapter ring
106	3	41005027	Vis STHC Ø5 x 12	Screw STHC Ø5 x 12

**CIRCUIT0 HYDRAULIQUE
VERSION MONOBLOC
MOTEUR ELECTRIQUE**

**HYDRAULIC FITTING
INTEGRAL TYPE
ELECTRIC ENGINE**

Le circuit hydraulique de l'ébavureuse est composé de
The hydraulic fitting of the shearing machine includes

- Une pompe (a pump)
- Un distributeur (a distributor)
- 1 jeu tubes et composants flexibles et rigides (*1 set of components, flexibles and steel pipes*)
- REP. REP 1-2 : Ref. 47701047
- REP 3-4 : Ref. 21334011

