

Track Report

The Journal of Pandrol Rail Fastenings 2001

TRACK SUPPORT SYSTEMS

- An Investigation into the reduction of short pitch corrugation formation in Milan Underground**pages 3, 4, 5 & 6
by G Diana, M Boccione, A Collina, Politecnico de Milano, Department of Mechanics, Italy
- The Tseung Kwan O Extension for MTR Corporation Limited, Hong Kong**pages 7, 8, 9 & 10
by Hayden Kingsbury, Engineering Manager, Barclay Mowlem
- The PANDROL VIPA System on the Podpeč Steel Bridge, Slovenia**.....pages 11 & 12
by Igor Baša, Chief of the Postojna, Track Maintenance Section, Slovenian Railways
- PANDROL VANGUARD on Railtrack**.....pages 13 & 14
by Derek Brimicombe, Railtrack Thameslink 2000 Project
- PANDROL VANGUARD Baseplate**.....pages 19 & 20 15 & 16

PANDROL FASTCLIP

- PANDROL FASTCLIP on Banestyrelsen**.....page 17 & 8
by Jan Faister Hansen, Banestyrelsen
- PANDROL FASTCLIP Baseplate Assembly on SEPTA**.....pages 19 & 20
by Tony Bahara
- PANDROL FASTCLIP on Georgian Railways**.....pages 21 & 22
by Tornike Kupatadze, Scientific-Technical Progress and Infrastructure Director,
Deputy of General Director, Georgian Railway

PROJECTS

- The Development of Resilient Fastenings for the Plantation Railways of the Australian Sugar Industry**pages 23, 24 & 25
by Robert James, Sugar Research, David Rühle, Mackay Sugar, Ken Gulbransen, CSR Sugar
- Development of the RT60 Turnouts**.....pages 26, 27, 28 & 29
by Tim Bessell, Corus Cogifer Switches & Crossings Ltd, UK

NEW PRODUCTS

- PANDROL FASTCLIP Baseplate Assembly**page 30
- PANDROL SAFELOK 3**page 31

Front Cover: PANDROL FASTCLIP installed on the recently opened TGV Méditerranée, where trains travelling at 300kph enable a journey time from Paris to Marseille in three hours.

Track Report is published by Pandrol Rail Fastenings Ltd.,
63 Station Road, Addlestone, Surrey KT15 2AR England.
Telephone: +44 1932 834500
Telefax: +44 1932 850858
E-mail: info@pandrol.com
Website: <http://www.pandrol.com>

PANDROL, PANDROL FASTCLIP, PANDROL 'e' Clip,
PANDROL VIPA and PANDROL VANGUARD are registered
trademarks of Pandrol Limited.

Pandrol Rail Fastenings gratefully acknowledge the
co-operation of all those contributing to the production
of this journal and who have given permission for the use
of photographs.

The technical information given in 'Track Report' was
correct at the time of printing, but the company
undertakes a continuing programme of research and
development, and improvements may have since
been introduced.

An investigation into the reduction of short pitch corrugation formation in Milan underground.

by G. Diana, M. Bocciolone, A. Collina, Department of Mechanics, Politecnico di Milano, Italy

An extensive on-site experimental test program on a new track system for underground railways has been in progress in Milan since December 1999. The on-site tests follow two preliminary phases of study carried out in the period 1997-99. The first covered the typology of track and the design and optimisation of its main parameters, and the second prototyping and laboratory testing.

The basic track system under development is known as the "Milano Massivo", and is composed of discrete concrete slabs (Figure 1), placed on four discrete rubber supports. Into the slab unit are embedded three wooden sleepers, each elastically supported on a continuous rubber layer. The rails are connected to the sleepers

by means of traditional fastening devices, incorporating a 5mm rubber pad.

Among the aims of the Milano Massivo track system were:

- a) a high capability for reducing vibration transmitted to the tunnel invert and consequently to the surroundings
- b) a reduction in maintenance requirements and an improvement in the capability to maintain the track geometry in the long term
- c) a reduction in the development of the short pitch corrugation that develops in the low rail of the sharp curves.

The first two objectives were successfully fulfilled. As far as the third is concerned, a clear advantage over ordinary discrete fastening systems was obtained, but no consistent improvement relative to other comparable slab track systems, such as

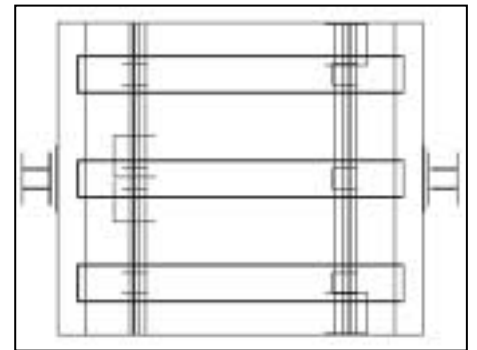

Figure 1: top view of Milano Massivo track system

the "Wien" system. However, although the Wien system exhibits good behaviour from the point of view of attenuation of transmitted vibrations, it showed maintenance problems related to the deterioration of the track geometry in the long term [1]. Therefore it was decided to improve the

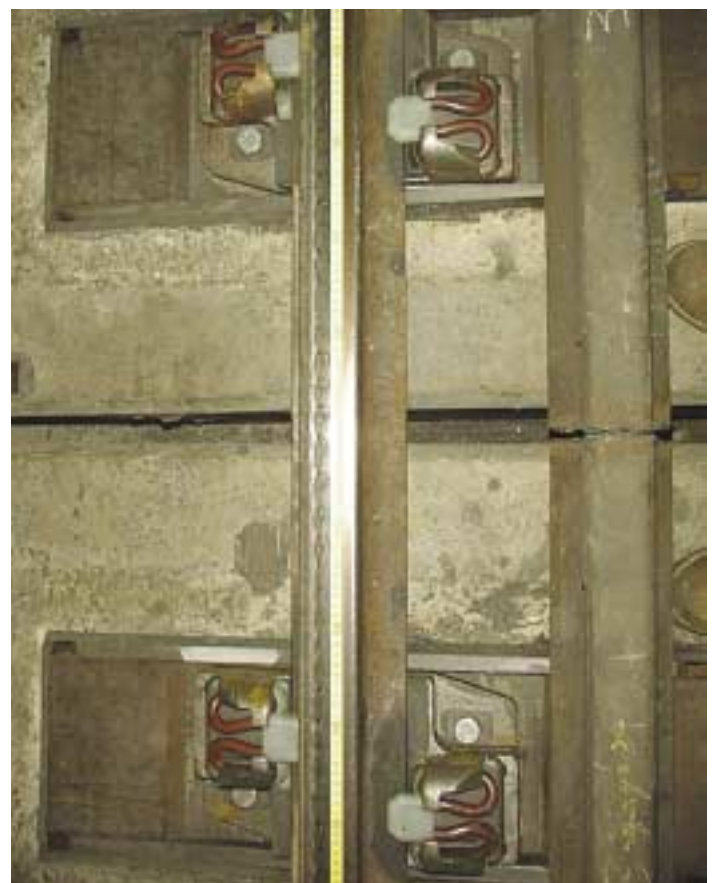
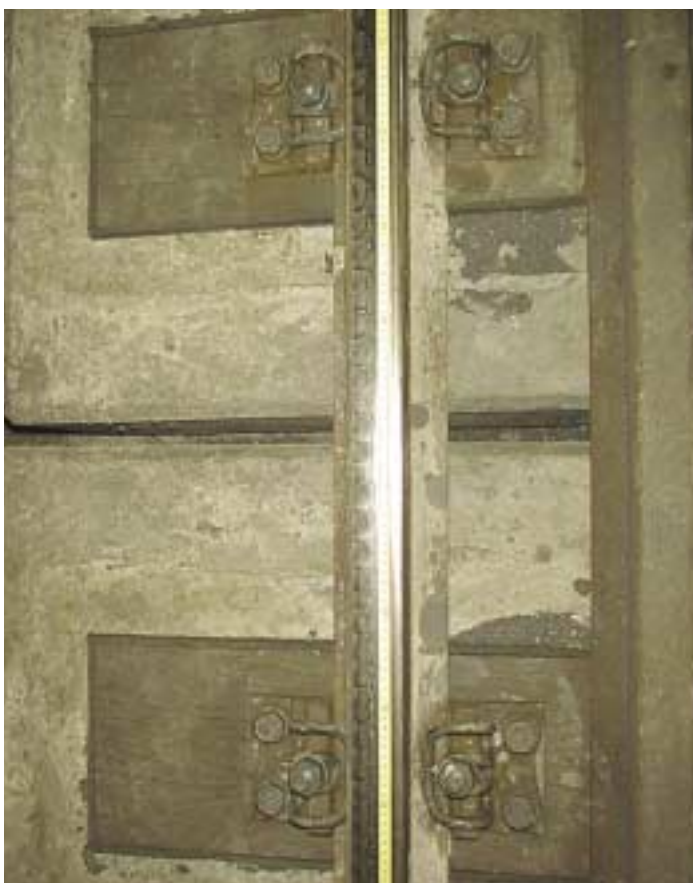

Figure 2: Milano Massivo slab track system with traditional fastening device (left) and with VIPA-SP system installed on the wooden sleeper (right).

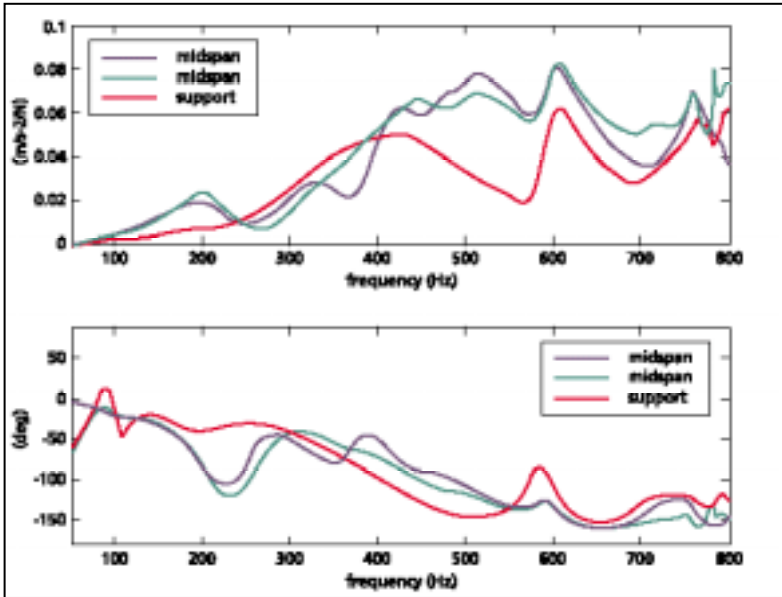

Fig 3a: Vertical inertance of the direct fastening track.

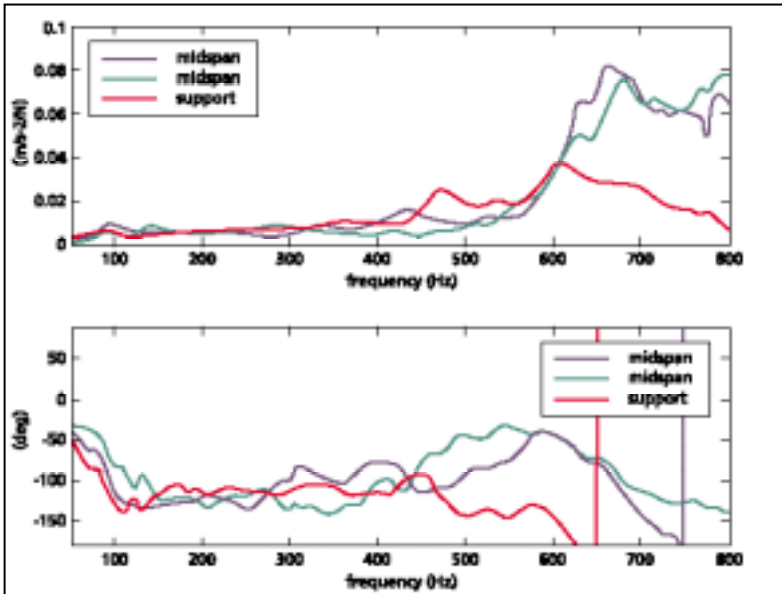

Fig 3b: Vertical inertance of the Milano Massivo track system with original fastening device.

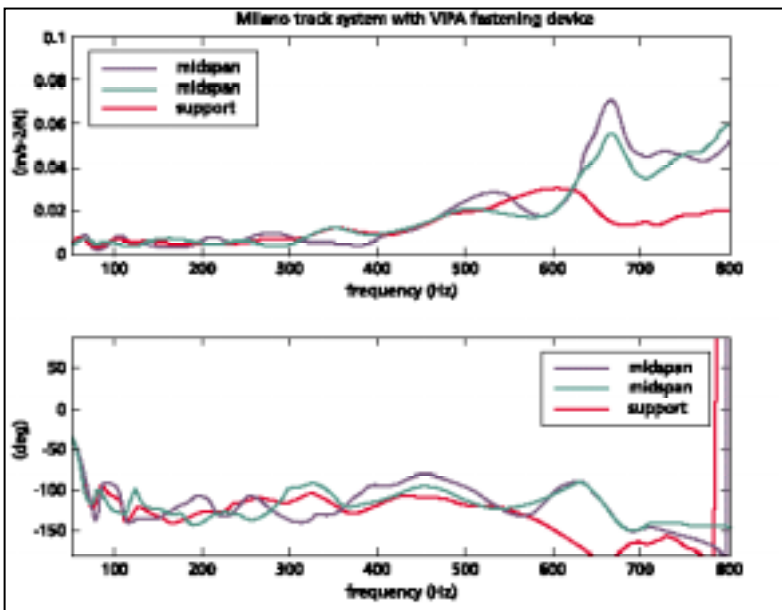

Fig 3c: Vertical inertance of the Milano Massivo track system with the VIPA-SP fastening device.

behaviour of the Milano Massivo with respect to the formation of short pitch corrugation. This work was based on the theory developed by the Department of Mechanics [3] identifying a mechanism of corrugation formation and its subsequent growth on sharp curves.

SUGGESTED MECHANISM OF FORMATION OF SHORT PITCH CORRUGATION.

At the test site, there are three different kinds of tracks. Two of these are slab track systems – the Wien and Milano Massivo types – and the third is a direct fastening system. This gave the opportunity to compare the different track systems under the same operating conditions. The curve radius is 170m.

Rail corrugations are found at the test site, and at other locations on the underground lines of Milan. These have the following features:

- a) rail corrugation appears only on the head of the low rail, in curves with a curve radius less than 200~250m;
- b) the wavelength and the rate of growth of corrugation are related to the track dynamic response, and its variation between the positions of the rail support and the mid-points between adjacent rail supports;
- c) tracks with stiff fastening devices show a considerable variation of vertical inertance even in the low-medium frequency range, as shown in figure 3a, for the direct fastening system, while resilient track systems show this variation at higher frequencies, as the Milano Massivo (figure 3b);
- d) tracks with stiff supports (like the direct fastening system) show a longer corrugation wavelength (around 8-12cm, see figure 4a), while more resilient tracks (such as the Wien or the Milano Massivo system), with a vertical flexural frequency (see figure 3b and 3c) in the range 80~130 Hz, are characterised by shorter wavelength of corrugation (around 2-5cm, see figure 4b and 4c)

On the basis of the above field observations, the wavelength fixing mechanism [2] of short pitch corrugation on the rail head in sharp curves can be explained as follows [3]. The variation of track inertance between two consecutive supports excites modes of vibration of the wheelset, inducing a variation of the vertical contact force. Consequently the tangential forces at the wheel-rail contacts vary with the same frequency, if a considerable mean level of creepage is present in the wheel-

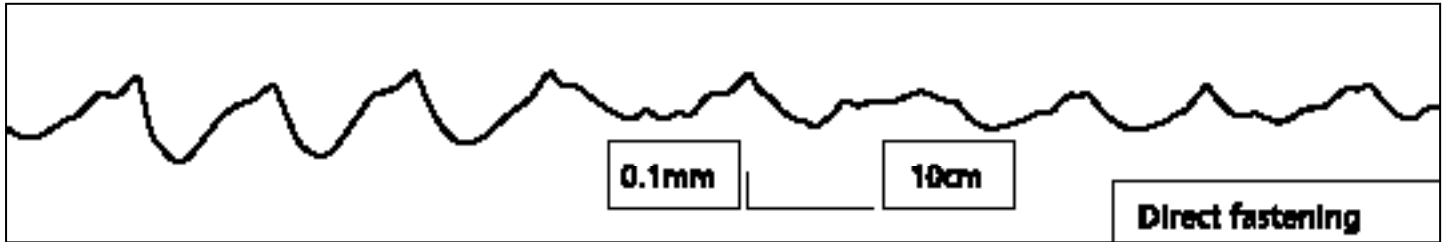

Figure 4a: Short pitch corrugation on direct fastening track (30 days after grinding operation)

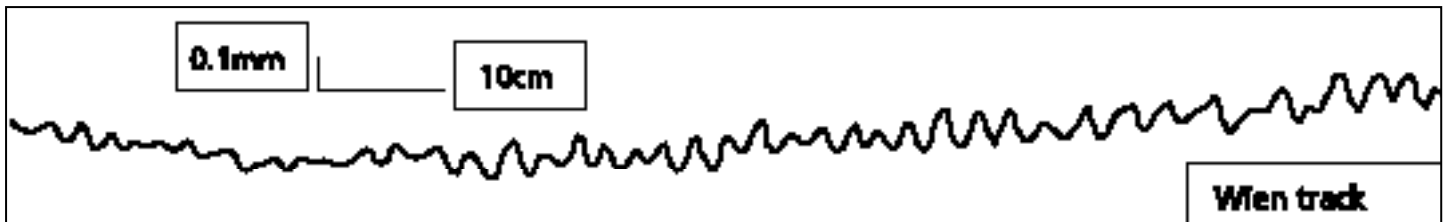

Figure 4b: Short pitch corrugation on Wien slab track (30 days after grinding operation).

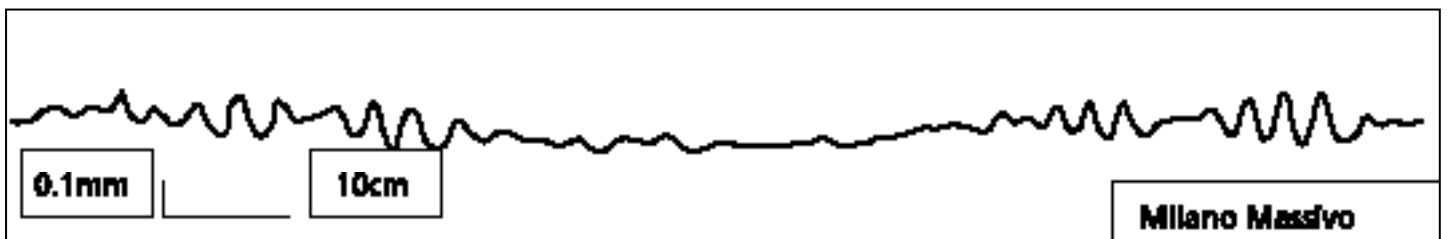

Figure 4c: Short pitch corrugation on "Milano Massivo" with traditional fastening device (30 days after grinding operation).

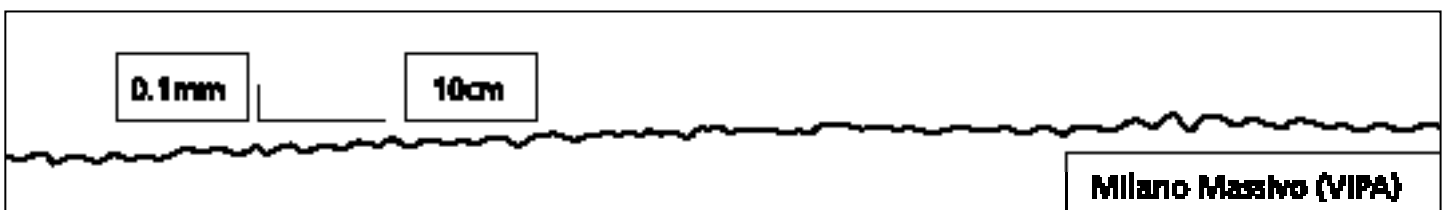

Figure 4d: Short pitch corrugation on 'Milano Massivo' with VIPA-SP fastening device (30 days after grinding operation).

rail contact (as is the case in sharp curves). The variation of tangential forces and the mean creepage produces a dissipation of energy that causes a periodic pattern of wear.

As to the different wavelengths and corresponding frequencies involved, it can be noticed that depending on the frequency range where the variation of track inertance takes place, different wheelset modes are excited preferentially. Therefore, if the track inertance variation takes place in the lower frequency range (such as for the direct fastening system), then the lower flexural and torsional modes of wheelset-rail system are excited. As a consequence, longer wavelength can be observed in the wear pattern on stiff track. On

the other hand, if the track inertance variation takes place starting from a higher frequency range (such as for the Massivo track system), then higher flexural and torsional modes of wheelset-rail system located in the higher frequency range of track inertance variation are excited. Consequently, shorter wavelength can be observed in the wear pattern of more resilient track systems.

This formation mechanism can explain why stiffer tracks exhibit a longer wavelength of corrugation. The proposed explanation is consistent with field observations concerning short pitch corrugation in sharp curves – that it is related to high creepage conditions. As a general conclusion it can be also stated that

track systems having lower variation of inertance along the rail are less prone to short pitch corrugation formation.

ADOPTION OF VIPA-SP SYSTEM FOR THE MILANO MASSIVO TRACK

From the above observations, it can be seen that in order to improve the wear behaviour of the track system, it is necessary to reduce the variation of track inertance along the rail. This variation is due not only to the stiffness of the fastening device, but also to the inertial effect of the sleeper. It should be noted that the Wien system has a sleeper made from a plastic material which has a mass lower than the wooden sleeper used

in the "Milano Massivo" system. The smaller lumped inertia under the fastening device in the Wien system is an advantage with regard to short pitch corrugation.

Following from these considerations, it was decided to reduce the stiffness of the fastening device that connects the rails to the sleeper by a factor of between 3 and 4. The aim of this modification is to achieve a dynamic de-coupling of the rail from the sleeper. A fastening device with a sufficiently low vertical stiffness must be able, at the same time, to guarantee the safe running – that is to limit track gauge variation as each wheelset passes. The required characteristics were found in the Pandrol VIPA-SP system. Under a general agreement between Politecnico di Milano and Pandrol Ltd, a program of research was then started under the supervision of ATM (the Transportation Authority of Milan). The following activities were carried out jointly:

- design of the modifications necessary to incorporate the VIPA-SP system on to the existing sleeper, without changing the rail vertical level on the test site;

- substitution of nine sleepers with the corresponding modified ones;
- on-site measurements and evaluation of rail wear growth.

RESULTS OF THE MODIFIED TRACK FROM THE ON-SITE TEST

The measurement set-up was designed to evaluate the main parameters of track behaviour, but here attention was focused on a comparison of the rate of growth of wear between two consecutive rail grinding operations. Figure 4 shows the measured rail profile over a length of 1m on (a) the direct fastening system, (b) the Wien system, (c) the "Milano Massivo" with standard fastenings and (d) Milano Massivo with the VIPA-SP fastening system. The elapsed time from the last grinding is 30 days. The reduction obtained with the VIPA-SP system, (Figure 4d) with respect with the traditional fastenings (Figure 4c) can clearly be seen.

The same patterns have now been found in four consecutive intervals between successive grinding operations. The observations give an indirect confirmation of the proposed mechanism

for the formation of short pitch corrugation. The rate of growth of short pitch corrugation with the VIPA-SP fastening system is about half that with the traditional fastening system on the Milano Massivo. As a consequence, the cost of maintenance due to grinding operations could be halved. The modified version of the Milano Massivo could be installed in those sections where it is required – that is in the sharp curves where the short pitch corrugation takes place. This generally corresponds to those curves with radius lower than 200–250m. ■

References

- [1] Bocciolone M., Cigada A., Falco M., Train structure interaction: measurement in the subway of Milan, Heavy Vehicle System, Int. J. Of Vehicle Design, Vol. 6, Nos 1-4, 1999
- [2] Grassie S.L., Kalousek J., Rail corrugation: characteristics, causes and treatments, Proc. of Instit. of Mech. Engrs., Vol.207D, pp57-68, 1993
- [3] Diana G., Bruni S., Cheli F. Collina A., Experimental and Numerical Investigation on Subway Short Pitch Corrugation, Suppl. to Vehicle System Dynamics, Vol. 29, pp234-245, Lisse, the Netherlands, 1998



Fig 5: pic caption here!!!!

Tseung Kwan O Extension for MTR Corporation Limited, Hong Kong

By Hayden Kingsbury, Engineering Manager, Barclay Mowlem

An MTRCL feasibility study commissioned in 1995 is now resulting in the construction of the Tseung Kwan O Extension (TKE) Project.

This ambitious project will, when operational in December 2002, provide rail transport to new communities in the Eastern corridor of Kowloon. This section of the Hong Kong mainland is one of the fastest growing development areas. The town of Tseung Kwan O is a rapidly expanding residential area, and there are new centres of population planned, which will also be

served by the TKE.

This will be the sixth line operated by MTRCL and it reflects a policy of responding to the ever growing needs of Hong Kong's transport infrastructure.

PROJECT DETAILS

Five new stations will be added to the MTRCL network. These stations are Yau Tong, Tiu Keng Leng, Tseung Kwan O, Hang Hau and Po Lam. A sixth station to be established later at Area 86 (in the south), will service residential developments

within its catchment. Area 86 is also the MTRCL depot facility for this section of railway.

The project involves extensive civil engineering and building works as well as track work, overhead line installation and the supply of rolling stock.

The civil contracts are complex and require formation of two large tunnel systems, the Black Hill Tunnels and the Pak Shing Kok Tunnels.

The Black Hill Tunnels are 1.8km long, but involved about 8km of tunnelling because there are four tunnels for two MTR lines, plus a 600m



Fig 1: Illustration of new rolling stock



long centre siding where services can be reversed or disabled trains temporarily accommodated. There are also six junction chambers and two crossovers between the Kwun Tong and Tsuen Kwan O lines.

The 6km Pak Shing Kok tunnels were excavated in a mixture of volcanic rock and granite. The tunnels have a complex configuration. The tracks start at the same level on leaving the depot but the departure track gradually rolls over the top of the arrival tunnel to join the main track from the future Tseung Kwan O South station. This creates three junctions, one which allows trains leaving the depot to enter a deadend siding, and two which allow the depot tracks to join the main tracks.

The TKE line is due to be fully operational by the end of 2002. When completed it will serve the current 250,000 population at headways as close as 105 seconds. Patronage is forecast to be over 200,000 passenger rides per weekday, rising to more than 750,000 by 2011.

Brand new rolling stock will operate on the line and 13 new eight car trains have been ordered.

The new line will be fully integrated with the existing Kwun Tong Line and will have interchange facilities with the Hong Kong Island

Line at Quarry Bay and North Point.

This 12.5km extension involves:

- 26 km of mainline track construction,
- 6 km of depot and maintenance lines
- 30 mainline turnouts
- 20 depot turnouts.

Barclay Mowlem, an Australian construction company, is the lead partner in the joint venture constructing the Trackwork and Overhead Line System phase of the work.

The joint venture of Barclay Mowlem, Zen Pacific Construction Company and China Civil Engineering Construction Corporation will complete the track and overhead line works by March 2002.

ENVIRONMENTAL CONCERNS

Hong Kong has some of the most stringent environmental impact legislation anywhere in the world. Besides controlling the amount of dust, toxicity, chemical seepage, fumes and other 'physical' sources of contamination, there are extensive safeguards against noise and vibration contamination. This is a particularly important feature in view of the proximity of the railway to residential and commercial dwellings.

A feature of the TKE railway is that it will

employ some of the latest available technology for the track in order to minimise the environmental impact of train related vibration. MTRCL have been perfecting different types of trackform and after extensive testing, now have a range of track types that are purpose built to reduce ground-borne vibration to an acceptable minimum.

TRACK DESIGN

The basic design criteria are:

- Track design speed 80km/h
- Axle load 18 tonne maximum
- Rail UIC 60
- Fastener spacing (on tangent track) 650mm
- Track gauge 1432mm
- Annual traffic approximately 50 million gross tonnes per annum

In all areas special forms of concrete slab track will be used. The slab track form consists of two types:

- Precast Concrete Block Trackform (PCBT); and
- Isolated Slab Track (IST) both of which have vibration attenuation capabilities.

PCBT (previously known as LVT or low vibration track), consists of individual pre-cast concrete blocks sitting on top of a rubber

microcellular pad. The pad and block are contained within a rubber boot. The PCBT is used in tunnels and at junctions where noise and vibration is not such a sensitive issue.

IST is a new trackform being used for the first time in Hong Kong. It consists of a concrete trough lined with natural rubber ballast mat. The ballast mat was selected after a rigorous testing exercise to check its ability to withstand the intended design life of 50 years.

Within the trough is another concrete block, which is effectively 'floating' and on top of this are special low stiffness baseplate fasteners.

IST is used in areas of future residential and commercial development adjacent to the railway which require extensive noise and vibration control.

An alternative trackform to the IST that was considered in the pre tender evaluations was Floating Slab Track (FST), but this was eliminated due to additional construction cost, extra construction time required and the fact that the IST trackform could attain the desired level of noise and vibration attenuation.

An essential element of the IST is the rail fastening system. Chosen on commercial and performance criteria is the Pandrol VIPA baseplate and Pandrol rail clips. VIPA consists of two studded natural rubber pads in series with two cast plates. The two plates are connected together using a boss and bush to provide vertical resilience but to restrict lateral movement.

TRACK CONSTRUCTION

Tracklaying started in January 2001, at the depot in the South and Po Lam station at the northern end of the extension.

The flash butt welder is kept static at each of the four main track access points at the depot, Po Lam, Tiu Keng Leng and Yau Tong. The 18m long rails are welded together to form long rails up to 180m in length. These are then rolled down along the inverts of the tunnels and eventually joined together by thermic welding.

At Po Lam, the flash butt welder has been set up in a small depot in an overrun area to produce track up to 500m in length. The main line track will be laid over a 45 week period, finishing where the extension joins the existing railway at Eastern Harbour Crossing.

In addition to tracklaying for the extension, a temporary depot with temporary trackwork adjacent to the main Tseung Kwan O depot has also been built, which will be the base for operation of electrical and mechanical works trains.

All trackform is being built using the "Top Down" technique which allows for a very fast and accurate method of track laying compared to other slab technology. This method of



Fig 2: Baseplates suspended from rail prior to concreting.



Fig 3: Baseplates are protected prior to concreting.

Fig 4: Concrete is pumped under the baseplates to the desired level.



construction requires the VIPA baseplate or pre-cast concrete block to be suspended from the rail at a predetermined spacing of 650mm longitudinally. The track is supported on specially made track supports and the alignment is checked by a recording trolley. Once the rail is set in position above the trough, concrete can be pumped in under the baseplate (or block) until it reaches the desired height level.

Special techniques are used during concreting to ensure minimal wastage and to prevent air-trapping beneath the track fasteners. Due to restricted access in tunnel locations, concrete has to be pumped distances of up to of 1.2km, hence great care has to be taken in both preparation and execution.

This method of construction means that there is no need for further adjustment of the track fasteners once they are concreted into place.

If necessary, VIPA does have the capacity for further lateral and vertical adjustment during subsequent maintenance operations. Lateral adjustment of $\pm 17.5\text{mm}$ is possible using specially designed serrated washers and matching teeth on the baseplate. Vertical adjustment of up to 20mm can be achieved using shims under the bottom plate. VIPA units, weighing 26kg, are delivered on timber pallets to the tunnel area. The relatively light weight per unit allows for easy distribution and installation.

THE FUTURE

The new TKE line is just part of an ongoing strategy for continuous expansion and improvement of the Hong Kong (SAR) transport infrastructure network.

The Hong Kong Government has worked out a plan for expansion of the rail network through to the year 2016 and beyond.

Apart from the TKE and other railways currently being built in the region, there are several more planned. By the year 2016, the network length would have doubled from its 1999 size.

By using the latest technology available and by continuing to improve, Hong Kong MTRCL will remain in the forefront of mass transit operations. ■

THE PANDROL VIPA SYSTEM ON THE "PODPEČ" STEEL BRIDGE ON THE PREŠNICA-KOPER LINE

By Igor Baša, B.Sc. (CE), Chief of the Postojna, Track Maintenance Section, Slovenian Railways

The electrified single-track line (DC traction) between Prešnica and Koper, Slovenia, was built in the year 1967 as a connection of the main port of the Republic of Slovenia with the European railway network. In this way the line facilitated the further development of the Port of Koper, making it one of the most important in the Northern Adriatic.

The track alignment runs along a picturesque but very difficult terrain. It is a little more than 30km long. However, it has to overcome the altitude of 440m with an average gradient of 2.1% and a maximum gradient of 2.7%. With regard to the variation of the terrain along which the alignment runs, it is worth mentioning that the first 21km of the line consist of 78% of

curves with a radius of 600m. Most of the curves have radii between 250m and 350m. Thus it is clear that the line can be considered a typical mountain line.

The line was built for 225kN axle load and a maximum speed of 70km/h, with a 150mm maximum superelevation of the outer rail in curves. The rails are S46, laid on wooden sleepers with resilient fastenings.

The line was designed to accommodate 1.5 million gross tonnes per year (brt/year); it is very near to the upper limit of its load and capacity. Therefore the construction of the second track to the Port of Koper is now on the priority list of the state investments in the near future.

As often happens in new construction, the investor was short of money during the

construction of the line and was therefore forced to use various cost saving measures, for example building-in of the old 40m long steel bridge, which was brought from an abandoned line to the location of a 500 year old small village, called Podpeč. The bridge was used for the bridging of a land slide, in which the conventional type of rehabilitation would have been irrational. Unfortunately, this solution, which was correct from the constructional viewpoint, was proved later to be a failure with respect to the noise pollution of the area.

Due to the specific position of the line, running along a steep slope immediately under the village, the unfavourable geological composition of the slope and the bad foundations of the old houses in the village, the



Fig 1: The Podpeč Steel bridge, showing proximity to adjacent houses.

vibrations and the noise caused by freight trains running past the village day and night have become unbearable for the inhabitants of the village of Podpeč. It was urgent to take some rehabilitation measures.

With regard to the financial possibilities of the Slovenian Railways and taking into consideration the noise and vibration, a rehabilitation plan was adopted, whereby initially the old improvised gangways were replaced with new ones, fixed firmly on the bridge structure and separated from the track. The old gangways were the main source of induced noise. The next step required the building-in of damping elements (resilient elements) between the track and the bridge construction.

The track across the bridge runs in a curve of $R=500$ m with a superelevation of 90mm and the longitudinal grade of 2.5%. The rails are continuous welded and fastened to the wooden sleepers (timber bearers), fixed to the steel bridge structure.

It was desired to build-in a system which could neutralise the intense vibrations, caused mainly by rough corrugation of the inner rail in the curve, which is a usual occurrence on this line. The annual increase in the height of the corrugations of the rail in the said curve was 0.4-0.5mm, therefore the rails need grinding every second year. In our opinion the cause for corrugations is the type of traction vehicles, which have two three-axle bogies (CC-type) each. This has a very unfavourable impact on the rails in sharp curves, especially in combination with high traction forces, when the train is not only hauled by the traction locomotive but also pushed by an additional locomotive at the end of the train.

After studying various options, we decided on the building-in of the PANDROL VIPA system, which met our requirements with regard to the damping of vibrations, low profile, simplicity of installation without any need to replace the sleepers, compactness, electric insulation etc.

Unfortunately, the usual PANDROL VIPA system did not include the possibility for the S49 rails, so the Pandrol engineers designed a modified VIPA system according to our specifications and sent the system to us as pre-assembled units.

The replacement of the old 'K' system base plates with the PANDROL VIPA plates, including the track adjustment, was completed without any problems in 6 hours of the track closure, taking into consideration that the new holes in the sleepers were drilled in advance. The drilling of the holes was performed using specially prepared templates. The completion of the work required

the use of the usual light track machines. The workers did not need any additional training, as the installation was straightforward.

A year after the rehabilitated track was put into operation, our estimates are positive. The noise and vibrations on the bridge and in its vicinity were reduced as expected, likewise the corrugation was reduced and the lifetime of the sleepers is expected to be longer due to reduced specific pressures under the base plates, which have a larger supporting surface than the previous 'K' type.

These experiences encouraged us to think about a further use of the PANDROL VIPA system in other locations. ■



Fig 2: Original K type fastenings.



Fig 3: PANDROL VIPA Baseplates secured to timber sleepers.



Fig 4: Finished track.

PANDROL VANGUARD ON RAILTRACK

By Derek Brimicombe, Thameslink 2000

This paper describes the installation and testing of PANDROL VANGUARD on a ballasted steel bridge, between Waterloo East and Charing Cross. The test site is close to the Royal Festival Hall in the South Bank Arts Complex and the London Eye, in central London. The trial was intended to demonstrate the practicality and effectiveness of the VANGUARD system and to gain further experience with this product under mainline conditions.

The VANGUARD system is a new type of rail fastening system in which the rail is supported by elastic wedges under its head. The wedges are in turn held in place by brackets, which are fastened to the track foundation. The principal advantage of the system, over more conventional rail fastenings, is that it allows significantly greater vertical deflections under traffic. This very low stiffness system reduces vibration transmission to the supporting structure, without an unacceptable accompanying degree of rail roll, and without increasing the overall rail height. When installed on a



VANGUARD Trial Site

bridge or viaduct, the resulting reduction in the vibration of the structure can lead to a net reduction in airborne noise alongside the track.

The trial site selected was 39m long on Underbridge 8A (Belverdere Road), which is 0 miles 33.5 chains from Charing Cross, on the up fast line from Waterloo East. The bridge comprises a riveted steel structure, approximately 14m x 19m wide, supported on brick abutments. The bridge carries four railway tracks passing over a road and footway, the tracks run on a viaduct on both sides of the bridge with brick railway arches beneath, some of which are in use – for example, as a public house and restaurant. Ballast depth on the steel deck was about 300mm below the bottom of the sleeper. The existing track comprised BS113A rail on timber sleepers in ballast, with PAN6 baseplates, a 7.5mm hard plastic rail pad, insulators and PR401A clips.

The Pandrol VANGUARD system was installed on new monoblock concrete sleepers, modified from type EF28. The junction between the two types of track form can be seen below.

In order to assess the effect of installing the VANGUARD system, pre-disturbance measurements were undertaken a few days before the planned changeover, to record the



Comparison of existing and VANGUARD track forms

performance of the existing track arrangement. The measurements included deflection and acceleration of both rails in the vertical and lateral directions, and acceleration of the rail seat in the vertical direction. Acceleration of the bridge structure was also measured and noise measurements were made at the wayside and under the bridge.

The ballast cribs and shoulders were then dug out and the existing wooden sleepers extracted. The ballast bed was riddled and the new VANGUARD sleepers installed. The sleepers were lifted to the correct height, and the fasteners clamped on to the rail web using the Pandrol installation tools provided. The ballast was then replaced and the track tamped. The installation went smoothly, without significant problems and after installation the line and level of the track were found to be good.

Immediately after the change to VANGUARD a repeat series of measurements were taken, as previously described. The same rail remained in place throughout the test period. Subsequent analysis of the recorded data showed the VANGUARD fastening system to be performing well, both mechanically and in terms of reducing transmitted vibration. Rail seat vibration was

reduced by 9dB(A) when compared to the existing track form, and vibration levels in the bridge vertical and lateral directions were reduced by an average of 6dB and 9dB respectively. The wayside noise level at a distance of 25m from the track was 3dB(A) lower than for the existing track, the noise level at a distance of 4m directly below the bridge was 6dB(A) lower. The noise reductions are believed to result from reduced vibration of the bridge structure.

All test measurements were made under normal traffic. This consisted of some new Class 465 and Class 466 trains, and also some older Class 411, 421 and 423 trains. The train speed was typically about 25kph. Axle loads are a maximum of 25T, with passenger trains having a typical axle load of around 16T.

The temperature when the measurements were made varied between 90°C and 130°C. The weather was fine and clear for the 'before' measurements, but there was rain in the later part of the day during the 'after' measurements. Due to this change in weather conditions, the noise measurement at 25m was repeated the following day when the weather was fine and clear again, with no perceptible change in the results.

The trial installation of the VANGUARD system went smoothly. The track is behaving within expectations from a mechanical standpoint. Vertical deflection of the rail relative to the sleeper increased from about 0.25mm to just over 4.5mm with the VANGUARD system fitted. Rail head lateral movement increased from 0.25mm to a little over 0.50mm. The VANGUARD installation gave significant reductions in wayside noise, even for the newest and quietest Class 465 and Class 466 trains.

COMPLETED TRACK IN SERVICE

The VANGUARD trial was installed over one weekend in October 2000 and regularly monitored over the following months. The system has been found to be stable and has required no adjustment or maintenance to date. Based on the experience gained during the installation, the performance monitoring, and with favourable reports from others associated with the trial, VANGUARD will be considered for further applications in the inner area of Thameslink 2000, where noise and vibration are sensitive issues. ■



Completed Track in Service

The Pandrol VANGUARD Baseplate

Trains ran over the Pandrol VANGUARD system in track for the first time on London Underground's Victoria Line in March 2000. Measurements have shown the system to be successful in its primary aim – reducing vibrations from the track – and the fastenings are performing well mechanically. For this first installation, the VANGUARD assemblies were built up around cast iron plates, which were set into a concrete sleeper at each railseat. The plates each link two 'shoulders', against which the VANGUARD fastener components are braced to react the rail clamping force applied by the assembly.

A concrete sleeper – replacing the hardwood sleepers normally used on the Tube system – was London Underground's preferred method of testing the VANGUARD system in its track, and it has a number of advantages. The sleeper design itself had previously been proven. Using a cast-in plate removes the need for bolts or screwspikes to hold the fastener to the track base, and consequently eliminates any risk of loosening or failure of these components. A concrete sleeper will not shrink away from the concrete into which it is set, presents no potential fire hazard, and there are fewer

concerns over reliability and sustainability of supply. Track built in this way should require significantly less maintenance in the long term.

However, the method also has some drawbacks. The trial installation of 120 metres of track had to be gradually installed during the very limited engineering hours available. The process of installation used was similar to that used to refurbish London Underground's tube lines with conventional fasteners. Here, the wooden sleepers are broken out of the invert into which they are set, and new sleepers are concreted into position in their place. For the VANGUARD trial,

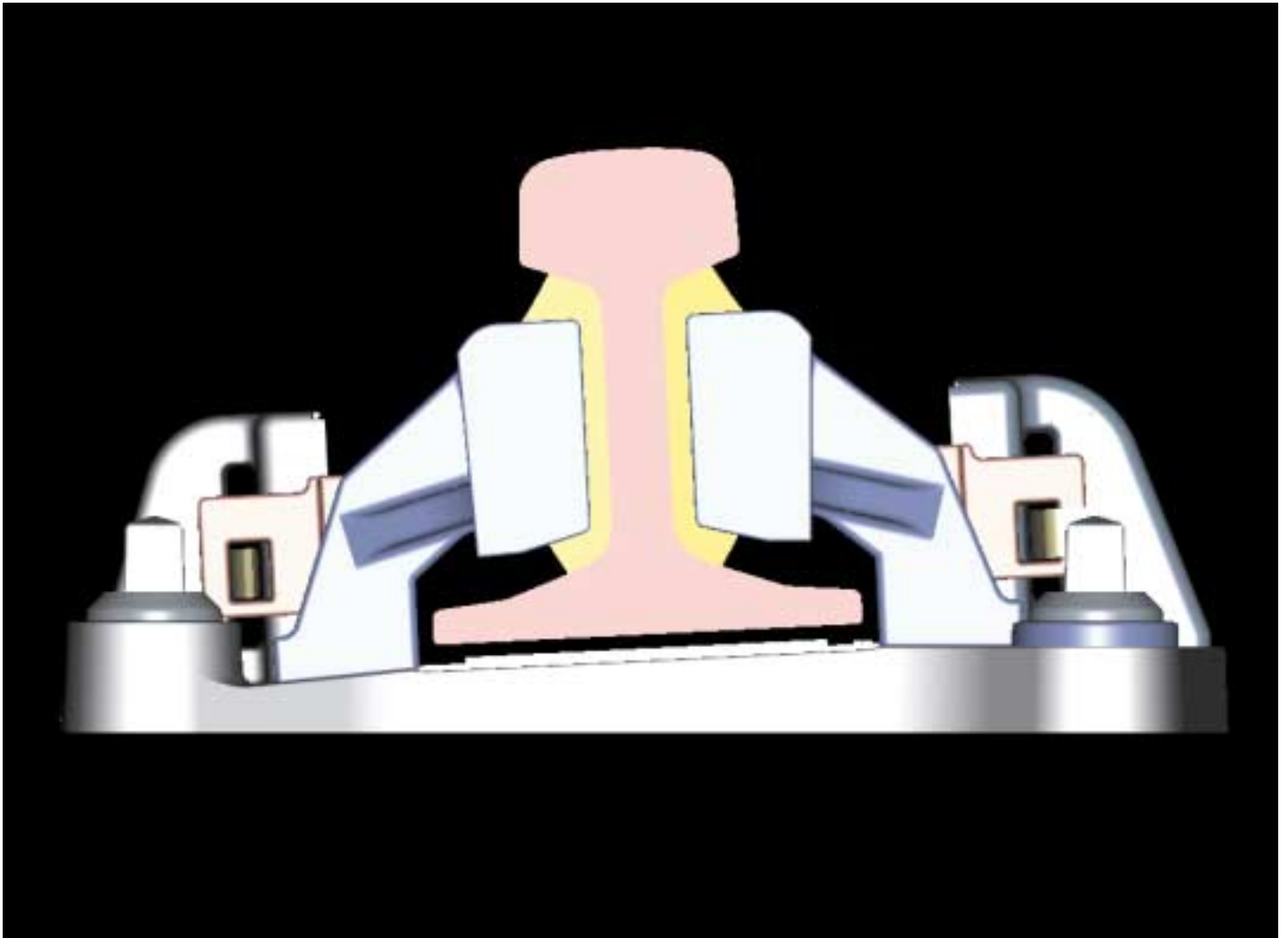

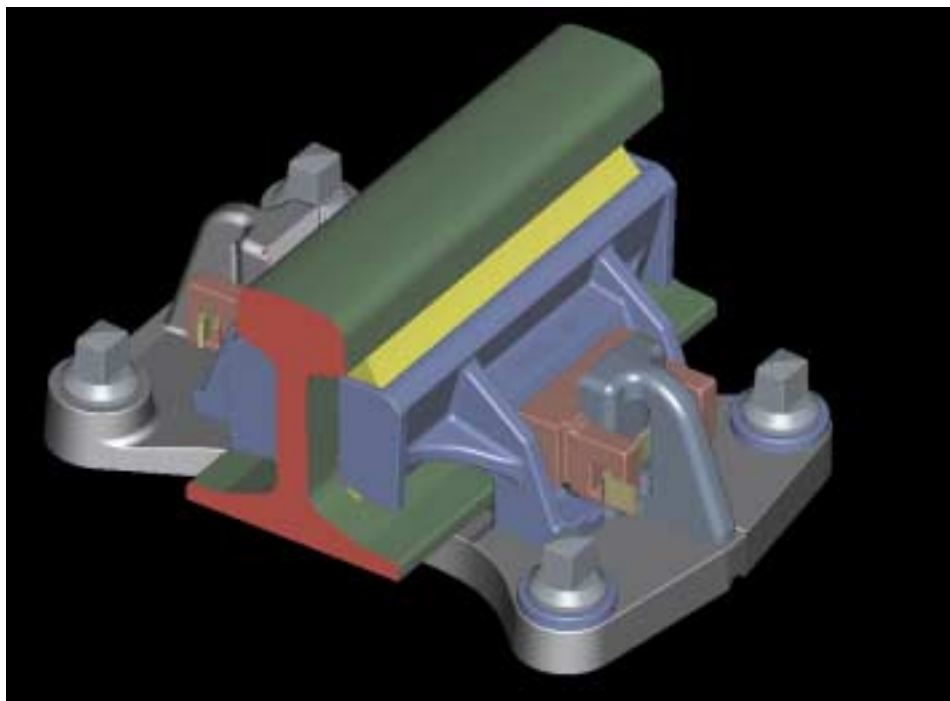

the wooden sleepers were retained, and new concrete sleepers were set into the concrete invert at mid-span between them. The amount of breaking out and concreting work is similar in both cases, and in either case, the installation process is slow and costly.

There is therefore a need for an alternative means of delivering the benefits of the VANGUARD system in terms of controlling vibrations which can be applied quickly and cost effectively to existing track so that greater lengths can be treated. The new Pandrol VANGUARD baseplate has been designed to provide this. It gives track with the same low vertical stiffness as the cast-in version. The baseplate is fixed to the track base by conventional means using bolts or screwspikes.

The initial design of a VANGUARD baseplate was based on London Underground's particular requirements. However, the same principles can be applied to designs for other railways faced with similar problems.

TECHNICAL CHALLENGES IN DEVELOPING THE VANGUARD BASEPLATE

- Height is at a premium in most railway tunnels. One of the great attractions of the VANGUARD fastening system is its ability to provide a very low stiffness in a very shallow assembly. This is particularly important in the case of London Underground. There is no possibility of raising the height of the rail head. Indeed, a requirement to change from the bull-head rail section that has traditionally

been used in the Tube to a deeper flat-bottom rail section has reduced the space available to accommodate the rail fastening. In the VANGUARD assembly, the 'shoulders' must resist any tendency to bend outwards in reaction to the forces applied to them. In the cast-in version of VANGUARD, these forces are resisted by the cast-in plate below sleeper-top level. In the new baseplate version, the depth of the plate gives it its strength, but this has to be provided within the overall height available for the fastening. Extensive laboratory tests on prototype assemblies have shown the new baseplate design to be easily capable of resisting the forces applied to it.

- One of the main reasons that the wooden sleepers on London Underground's tube track eventually need to be replaced is that the screwspikes used to hold the plates down loosen in their holes and cannot be re-tightened effectively. While the holes can be plugged, and the plates can be repositioned across the width of the sleeper to create new hole positions, eventually the sleeper cannot be used any longer. A survey was carried out on as many as possible of the many different types of baseplate currently used in the Tube. The positions of the fixing holes in each were identified, and an entirely new and different pattern of holes was identified for the Pandrol VANGUARD baseplate. This means that even where it is to be fixed to existing wooden sleepers, the holes can be drilled into fresh wood, offering the potential to extend

significantly the useful life of existing sleepers.

- The 'shoulders' in a VANGUARD fastening assembly stick up higher than those on a conventional Pandrol 'e' clip type assembly (though not as high as the chairs used to fix bull-head rail on London Underground). One reason for this is to allow the height of the rail to be adjusted in the vertical direction within the assembly. This allows local adjustments to be made where lengths of rail with differing head wear need to be joined. This was an essential requirement for the cast-in version of VANGUARD, where no other possibility for height adjustment exists. In a baseplate version, the traditional method of shimming under baseplates to adjust height could be employed. However, loosening the screwspikes that hold down the plate contributes towards the long term degradation of the sleeper and reduces its life. For this reason, the option of adjusting rail height within the assembly was retained in the baseplate version. Consequently, the 'shoulders' stick up to a similar height to those on the cast-in version. This could have created a difficulty when the plates are installed. The rail would need to be jacked up above the shoulder height to allow it to be slid into place. This potential problem was overcome by developing a hook-in shoulder, which is used on the field side of the plate. This is introduced only after the baseplate has been fed in under the rail. The clamping forces applied to the rail once the fastener has been assembled holds the hook-in shoulder firmly in place. Its use means that the London Underground VANGUARD baseplate can be slid in and out from under the rail from the centre of the track without any need to jack the rail at all. This offers potential for easier and quicker maintenance operations in the future – though of course the rail still needs to be jacked sufficiently to allow the old baseplates to be extracted when the VANGUARD baseplate is first installed.

Variations on the basic Pandrol VANGUARD baseplate design have now been developed to make it suitable for use in a number of specific applications on different railways. Trials of the Pandrol VANGUARD baseplate system are planned on a number of railways in the near future. ■

Installation of Direct Fixation Fasteners on the Southeastern Pennsylvania Transportation Authority (SEPTA), USA

By Tony Bahara, (Job Title?), SEPTA

The Southeastern Pennsylvania Transportation Authority (SEPTA) is presently renewing Direct Fixation Rail Fasteners (DFF) on a 1.3 mile section of the Broad Street Subway. The use of direct fixation and direct fixation fastenings was new to the industry when the South Broad Extension was under construction in 1970. Time has proven this particular design to be a poor performer for the adverse tunnel environments at SEPTA, as well as other transit agencies such as the NYCTA and the Toronto Transit Commission. The present project, which will completely replace the old DFF assemblies with a PANDROL FASTCLIP DFF assembly will be completed by FY 2003.

The South Broad Street Subway Extension is the southern end of SEPTA's Broad Street Subway line. A reinforced concrete tunnel with tracks fixed directly to the floor slab was the form of construction chosen. The subway utilises a DC electric third rail system to power the subway cars and the running rail is also utilised for electric traction power negative return. The South Broad Street Extension is below the level of the Delaware River and water is present throughout the tunnel. Water, DC current and poor insulation have resulted in a serious electrolysis problem. The problem reached the point where the existing DFF assemblies could no longer be repaired, necessitating the installation of new ones.

The solution to the problem was to develop a DFF assembly that could be installed without affecting daily rail service, and would also be economical to fabricate and install. In many cases, the configuration of the existing tunnel track construction required the installation of new assemblies over the anchorages of the old assemblies. To achieve this goal the new DFF plate was designed to allow the installation of the new anchor through the plate after the fastener was located in its final position.

One of the keys to the DFF replacement has been the productivity achieved by a dual head coring machine that was developed by PTC Fastenings. The holes for the new anchors are cored in the concrete support slab without disturbing the track. The new plates are located



Existing DFF assembly.

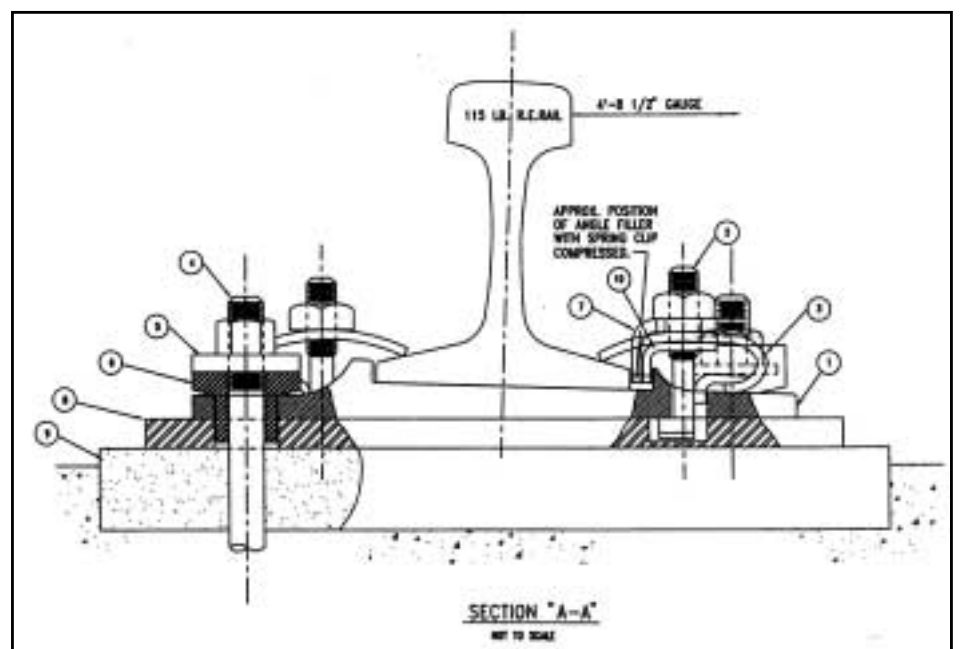

Pic caption here!!!

over the holes and the anchors are inserted through the plates and permanently fixed with an acrylic resin adhesive.

The Pandrol FASTCLIP assembly is shipped fully assembled with all of the components – elastomeric pads, clips and insulators – attached. The fully assembled fastening minimises many of the logistics problems that have been experienced with other fasteners. Not only are all the parts there for installation, but there isn't any chance of assembling the fastenings incorrectly. The Pandrol FASTCLIP plate is a non-bonded system and is somewhat similar to fixation used on concrete ties.

Pandrol will furnish an additional 11,000 FASTCLIP Direct Fixation assemblies to complete the replacement of the old rail fastenings. Approximately 6,000 new DFF assemblies have already been installed. The new fastenings have been performing well and no problems are anticipated. ■



Pandrol FASTCLIP assembly.

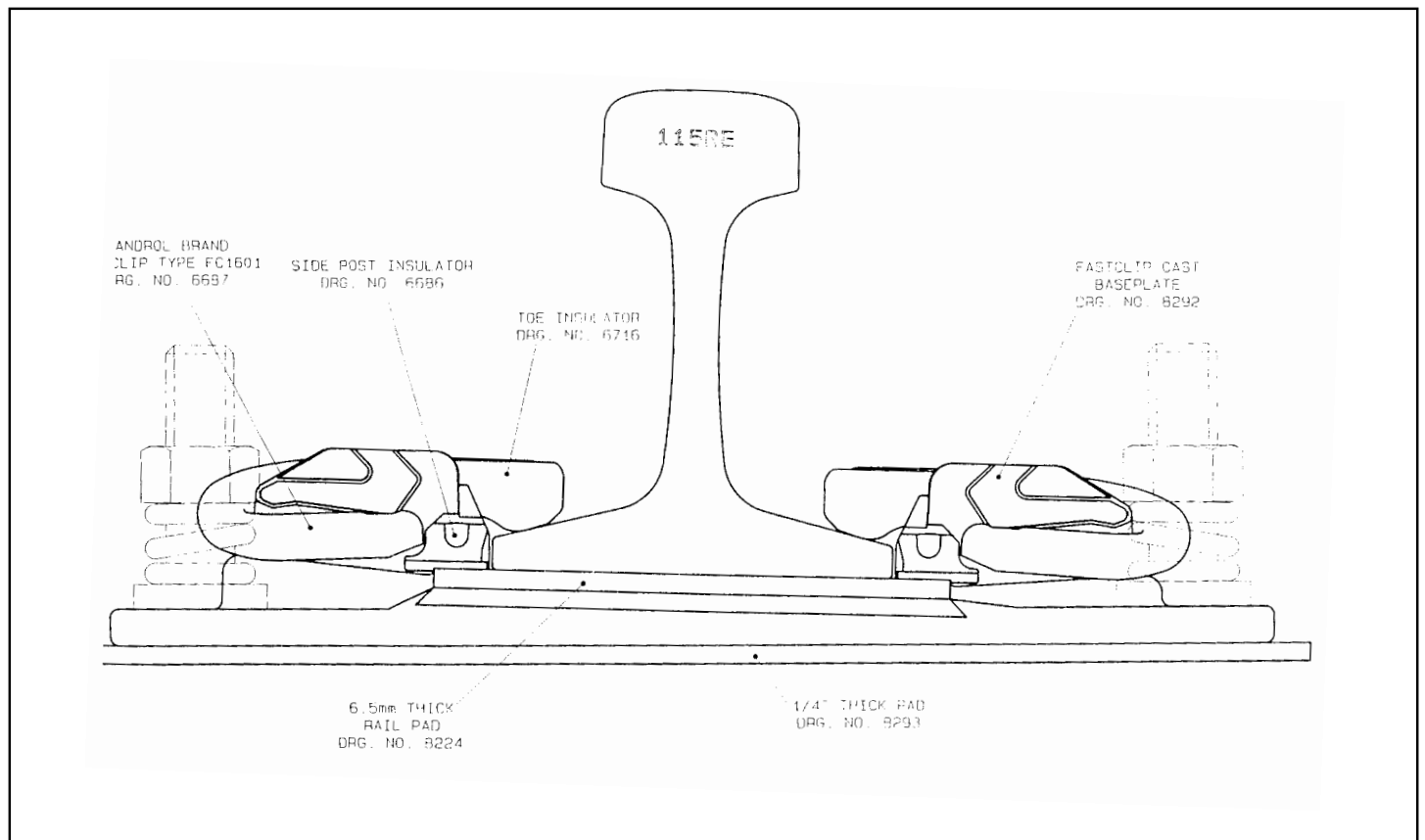

PIC caption here!!!!

PANDROL FASTCLIP on Georgian Railways

by Tornike Kupatiadze, Scientific-Technical Progress and Infrastructure Director, Deputy of General Director, Georgian Railway



The Georgian Railway is a vital artery linking the Black and Caspian Seas, and an important part of the Euro-Asian Transportation Corridor – the shortest route between Europe and Central Asia, the North and the South.

The Chief sector of the Georgian Railway, Samtradia – Tbilisi – Baku, is a double track line. From Samtradia, single track lines lead to the sea-ports of Batumi and Poti and further, via Sokhumi into Russia. Another important sector is the one to Armenia. A single track rail line between the Georgian capital Tbilisi, and that of Armenia, Erevan, continues into Iran, serving as a link

between the Black Sea ports and the Gulf. Several rail line spurs connect some of Georgia's significant industrial and resort areas with a central rail line.

Recent developments in Georgia prompted change to the existing rail system into a much needed transit route within the Euro-Asian Transportation Corridor. To this end a regional TRACECA project involving updating of the Azeri and Georgian Rail Infrastructures was drawn up jointly with German experts, along with a further agreement, The Logistical Express Technology Scheme, envisaging rail and container shipments by the state-run rail

lines in Azerbaijan, Armenia and Georgia (Poti-Baku-Poti, Poti-Erevan-Poti), made operational between 1996-1997.

The 3rd Pan-European Transportation Conference opened in Helsinki on 25th June 1997, and recognised the part of the Euro-Asian Transportation corridor running through Georgia as a high-priority issue, and Georgia joined the Pan-European Area. Georgia has been marked by transit signs on the EU maps.

The railway system is a major contributor to the national economy, retaining its significance in a continuing transportation boost to market economy, given the level of freight and passenger traffic built up over the last few years.



The market economy in the recent past in Georgia has been unpromising, created by a reduction of production and an economic instability leaving an imprint on the operation of the railway. In 1988 36.2 million tons of freight were shipped by rail in Georgia, the amount in 1995 decreased to 4.7 million tons - a mere 13% of the rail capacity. Freight shipments however have continued to recover ever since, reaching 9.5 million tons in 1999.

Azeri and Kazakh oil is now being shipped to Poti and Batumi by the Baku-Tbilisi-Samtradia double track electric line, where it is shipped, in oil tankers, to Europe and the rest of the world.

Rail ferry passageways have been constructed in the Georgian seaports Batumi and Poti and ferries between Poti-Ilichovsk and Batumi-Ilichovsk have been put into operation.

In the past, Georgian Railways demand for concrete sleepers was satisfied by supply from Russia and Ukraine. Fastenings traditionally used with these sleepers were the rigid KB Type. As a result of changing circumstances, other sources of supply came under consideration. The Georgian Railways leadership evaluated both elastic fastenings and a sleeper more suited for use with such a fastening type.

Following a period of technical assessment, during 1999 Georgian Railways entered into contracts with two British companies; Pandrol UK for the supply of the PANDROL FASTCLIP self tensioning elastic fastening system and with Ranalagh Moulds for the supply of a new sleeper manufacturing plant to produce a new sleeper designed to meet the demands of the Railways rehabilitation needs.

The sleeper plant was constructed on the site of another Tbilisi based ferro-concrete factory

functioning as a distribution unit. Currently the capacity of the factory is 200 sleepers per day, 70,000 sleepers per year. The factory has made it possible for Georgia only partially to meet its sleeper demand. As a consequence of Georgian Railways commitment to rehabilitate and upgrade the railway system, there are plans to build at least one further sleeper production line in the near future.

It is the intention of the Georgian Railways, once sleeper production rates are able to satisfy the demands of the railways track rehabilitation and upgrade programmes, to consider exporting new sleepers to neighbouring countries. If sufficient interest can be generated to support this idea, the Georgian Railways will consider the installation of a third production line. This will ensure capacity to meet both local and export demand.

Utilising the combination of the new sleeper and the PANDROL FASTCLIP rail fastening system, at the time of writing, Georgian Railways has built 12.5km of new track and is about to embark on a new project to construct a new 1.5 km rail line between Gori and Uplistsihe. These new sleepers with PANDROL FASTCLIP will be widely used during the construction of all new railway tracks.

The PANDROL FASTCLIP self tensioning elastic fastening system was chosen by the Georgian Railways following a period of both technical and economic assessment. Other fastening types were considered including those manufactured and supplied by other elastic fastening suppliers, Vossloh and Stedef.

PANDROL FASTCLIP for the Georgian Railways were based on the considered benefits of the fastening system to a railway utilising a long established panel laying track construction method.

- Ease of use of the fastening system from pre-assembly at the sleeper factory through to the track laying procedure and eventual de-stressing of the rail with all the components remaining captive on the sleeper and no potential for component loss.
- The use of simple, easy to use hand tools in the short term with the potential to deploy mechanical extraction/installation machines at a later date should they be required.
- A non-threaded system with exceptionally durable components providing a pre-determined toe load to the rail foot – with the long term maintenance savings directly associated with a maintenance free fastening.
- The initial competitiveness of the system and the considered whole life savings associated with its exceptional longevity.

The Georgian Railways have a contract with Pandrol for the supply of 100,000 PANDROL FASTCLIP sleeper assemblies per year for the next 10 years. To date over 100,000 sleepers have been produced and there are already a total of 45km in track, and whilst the sleeper/fastening will remain under observation, the Railways look forward to enjoying the benefits associated with the sleeper/fastening combination long into the future. ■



Sleeper plant.

The Development of Resilient Fastenings for the plantation railways of the Australian sugar industry

by Tim Bessell, Corus Cogifer Switches & Crossings Ltd, UK

Sugar cane is grown in Australia along a 2000 kilometre coastal strip from the Northern Rivers District in New South Wales to the Mossman District in the northern part of Queensland as shown in figure 1. In 1999, 36 million tonnes (95%) of this cane was transported from the farms to processing factories by 610mm gauge railway systems, which are owned and operated by each of 23 individual factories. The cane is transported during a 140 day period from June to December over 4,300 route kilometres of track by about 240 diesel hydraulic locomotives of up to 40 tonnes mass with powers up to 530 kW. The 55,500 four wheel wagons have a carrying capacity of 4 to 10 tonnes. A small but increasing number of bogey vehicles having capacities of 11 and 14 tonnes are used to transport some cane and sugar at four factories. An average factory crushes 13,500 tonnes of cane per day.

HISTORY

When the Australian sugar industry was established late in the 19th century, sugar cane was manually cut and loaded onto flat topped four wheeled wagons of about two tonne capacity. These wagons were then hauled (often by horse teams) along portable railway track from the field to the main line where they were transferred to the factory by steam locomotives. This system served the industry well until the 1950's when 140 kW diesel hydraulic locomotives were introduced and mechanical harvesting of the cane led to the eventual elimination of portable track. In the ten years from 1960, tracks were extended into new growing areas and train speeds increased. Except for the introduction of prestressed concrete sleepers and an increase in rail size from 20kg/m to 31kg/m few improvements to the track structure or maintenance practices were implemented even though increased tonnages at higher speeds were being handled. After 1970 as tonnage hauled and train speeds continued to increase it became evident that the track generally was inadequate for this increased service.

THE TRACK

Most sugar cane in Australia is grown on or near alluvial flood plains of coastal streams. Because they must be conveniently located within these growing areas, cane railways must often pass through terrain or follow alignments which would not normally be selected to produce an efficient low cost railway system. Easements through farmer owned paddocks are often only 2.5 metres either side of the track centreline. All

drainage and any access roads for maintenance must be provided within this easement. In the far north of the growing area where rainfalls often exceed 4,500 millimetres per year, adequate drainage is often difficult if not impossible to provide and the track, which until recent times was laid on uncompacted natural earth formations, is often waterlogged for weeks at a time during the off crop period from December to June. In spite of these difficulties, good top and line must be maintained to avoid derailing the torsionally rigid, unsprung four wheeled wagons used by all factories.

CANE TRAINS

A typical cane train has 200-250 wagons of 4 or 6 tonne capacity hauled by a 32 or 40 tonne diesel hydraulic locomotive powered by a 530kW engine. The wagons are invariably unbraked but most large trains have radio controlled brake wagons of 24-32 tonnes mass coupled to the last wagon of the train. Wagon couplers vary from simple hook and ring with centrally located fabricated steel buffers to small versions of automatic couplers similar to those used by major railway systems worldwide. These four wheel wagons are about 3.3m long over the couplers and have a tare of about one tonne. Gross train masses of 1000 to 1250 tonnes are common.

The most recent 530kW 40 tonne locomotives can haul these 1250t trains at 40 km/h on level track but will "lug down" to 6 to 9 km/h on grades which are frequently as much as two percent which also requires splitting of the train. Handling a long unbraked train of 1250t mass is difficult even with a remote radio

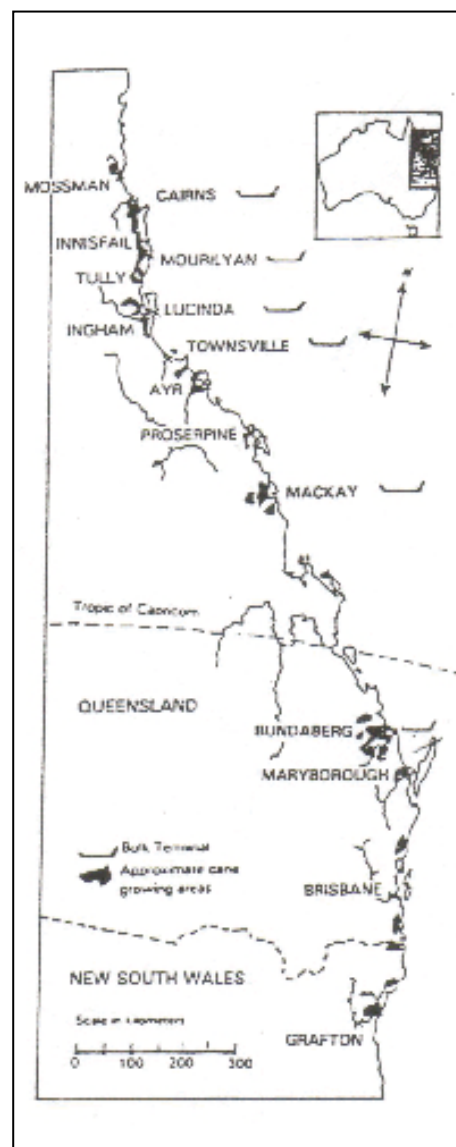

Fig 1: Distribution of the Australian sugar industry.

controlled brake wagon because locomotive loads are designed to utilise fully the adhesive power of the locomotives. This means load design coefficients of adhesion of 0.35 or more are frequently achieved. Because of the buffering effects of the loose coupled wagons, the effective adhesion during braking is significantly lower. The combination of these factors presented the industry with several problems not least by the eventual failure of the rail to sleeper fastenings.

FASTENING DEVELOPMENT e-CLIPS



When prestressed concrete sleepers for eight tonne axle loads were introduced 30 years ago, truly resilient fastenings were not developed although several types of fasteners manufactured from spring steel found acceptance. The Pandrol CF2 was part of this group. The lack of fastener elasticity was not detrimental to either the sleeper or its performance in track until about 1982 when, as tonnages hauled, train speeds and lengths continued to increase, it became evident that both the sleeper and fastening system were inadequate for the increased duty.

Failures occurred for two reasons. Firstly, the 1200mm long 42kg concrete sleeper was found to be too small for the higher duty resulting from increasing speed and tonnages carried. The comparatively small sleeper and hence low track modulus led to rapid deterioration of track geometry thus increasing the derailment potential of the four wheel unsprung, unbraked wagons as well as increasing the maintenance load.

The second effect was failure of the fastening. At that time most canefield locomotives were rigid framed 0-6-0 designs which have a large reversing gearbox behind one buffer plate, the buffer plate at the other end of the locomotive being increased in thickness to compensate for the gearbox mass. As speeds increase the lateral (flanging) forces generated by these locomotives on the head of the rail also increases. The absence of any significant fastening toe load allowed the rails to rotate about the field side foot under the influence of the lateral forces. At some locations, particularly on the high rail of small radius curves (<150 m), the forces were large enough to permanently deform the heads of the fastening, which in turn led to loss of gauge and ultimately vehicle derailment. At that time (1982) future planning also suggested that axle loads would increase to 12 tonne during the next 10-15 years. In the



Pandrol 'e' clips in track.

period between July 1990 and June 1991 forty tonne four axle locomotives entered service.

To meet this need, Pandrol Australia in conjunction with the Sugar Research Institute and Austrak Pty Ltd co-operated to develop a completely new 12 tonne axle load concrete sleeper and fastening system. The fastening system was based on the light duty Pandrol 'e' 1200 series clip and shoulder used in South African mines. In-service trials of sleepers and fastening systems commenced in 1986, and full scale production for Australian sugar mills was in place by 1989. The system can accept both 1200 and 1400 series 'e' clips each providing nominal toe loads on 31kg/m rail of 4kN and 5kN respectively. Because the low axle loads combined with low track speeds (by comparison with larger gauge national and other private railway systems) produce comparatively low rail to sleeper impact loads resilient pads between rail and sleeper are not used. There is no evidence of rail seat cracking or erosion at mills even where several eight tonne axle load locomotives have been in service for up to thirteen years.

'e' CLIPS IN SERVICE

Although the 'e' clip was far superior to other fastening systems in use at that time, the need for a low profile, more robust, easier to install fastening, required to meet the type of conditions imposed by cane railways, emerged. The low speed, low axle load operations of cane railways which carry a low bulk density low value material means a larger number of derailments can be tolerated by comparison with national rail systems, especially when higher costs of both track and rolling stock maintenance or construction, to minimise these derailments, are considered.

This balance results in a higher number of derailments than would be accepted by other rail operators. During derailments although sleeper damage is not considered excessive, the higher profile 'e' clips can be deformed or dislodged when struck by wheel flange of the derailed wagon which is usually carried by the couplings of the adjacent wagons with the wheel flange just above sleeper level. Deformed clips result in loss of toe load as well as making the clip unserviceable.



Pandrol CANECLIPS in track.

The pressed metal shoulder is also frequently damaged such that fitting a new clip is impossible. Thus installing new fastenings to an existing damaged sleeper is difficult if not impossible in some cases. It was also identified that a number of safety issues needed to be addressed with the existing system. Damage from dislodged clips and the need to provide improved installation methods to ensure workers safety during manual installation were recognised. In 1996 Mackay Sugar discussed these experiences with Pandrol Australia, the result being the development of the flat profile Caneclip.

CANECLIPS IN SERVICE



In 1997 two track sections were established at locations where seasonal (140 days) traffic was 1.7 and 2.6 million tonnes of cane. Both sections

were located in tangent track adjacent to large radius curves. The clips used for these 100 sleeper sections were 14mm diameter. The clips which were installed into pressed steel shoulders cast into the 1370 mm long concrete sleepers produced a toe load of about 6kN. Following installation, toe loads were measured at each location. Additional monitoring was also undertaken during the trial period.

At this time 72 metre lengths of welded rail were being introduced. The higher toe load produced by Caneclip provided additional track stability.

During the trial period of two seasons each of about 22 weeks in excess of 8 million tonnes of cane passed over the sections. During this time at least two derailments occurred at the Mackay Sugar site. Although some of the 'e' clips either side of the shoulder by the wheel flanges with collateral shoulder damage making the sleeper unusable or some were so badly deformed that significant or all loss of toe load resulted, all Caneclips remained in place; shoulder damage was minimal and all test sleepers and Caneclips remained in service. Subsequent measurements showed only very small toe load losses. Although the relatively low wheel loads of 1.75 – 2.0t was a contributing factor, by far the most significant influence on this result is the flat profile of the Caneclip compared with the higher arch profile of the e-clip.

When installing the Caneclip test sections,

other advantages provided by the Caneclip design were noted, principally:

- Caneclips are more easily and safely fitted and removed by manual means than the e series clips.
- The flat profile of the Caneclip means the direction of fitting into the shoulders can be reversed. This makes the clip a more versatile fastening because sleepers either side of a suspended mechanical joint can be placed immediately adjacent to the ends of the angle type fish plates widely used by cane railway systems.

INDUSTRY ADOPTION

In 1999, following the two season trial period Caneclip was adopted as the preferred concrete sleeper fastening for new track and face and spot re-sleeping by 15 raw sugar factories operating 2840 kilometres of 610mm gauge track. The track is about 68% of the total route kilometres in the Australian Sugar Industry. The fastening assembly has been enhanced by the development of a ductile iron shoulder to replace the pressed steel type used for the test sections. As well as being more robust the ductile iron shoulder simplifies maintaining the accuracy of its location in the sleeper mould during casting. A modification to provide an insulated assembly for circuitised track used to activate flashing light assemblies at road-rail level crossings is being considered. ■

RAILTRACK, RT60, SUNDERLAND LAYOUTS

by Tim Bessell, Corus Cogifer Switches & Crossings Ltd, Scunthorpe UK

Corus Cogifer Switches & Crossings Limited (formerly Grant Lyon Eagre) have designed and built RT60 Turnouts based on CEN60E1 (UIC60) rail and CEN60E1A4 (60D tongue rails) for the Sunderland renewals. This project paper presents the design philosophy and describes the salient points of the build and design. (Figures 1, 2, 3)

The design has been developed by Corus Cogifer in conjunction with Cogifer S.A.

DESIGN PHILOSOPHY

The design philosophy has been based on the following remits.

- To fulfil the Railtrack brief for an RT60 inclined design on concrete bearers, capable of carrying a 30 tonne axle load.
- To simplify the inclination of the rail through the turnout.
- To minimise componentry and the variety of components.
- To minimise lifetime maintenance, inspection regimes and procedures.



Fig 1: Pic caption here!!!!



Fig 2: Pic caption here!!!!



Fig 3: Pic caption here!!!!

Rail Inclination

The question of how to incline the rail was considered very early in the design process as the key element.

The various methods considered were:

- Inclining the rail by rolling the inclination into the web or head. This may have led to restrictions of supply of replacement rails in the event of renewal, maintenance or replacement. Replacement rails would have



Fig 4: Pic caption here!!!!



Fig 5: Pic caption here!!!!

- had to be 'handed' (LH or RH).
- It would have introduced another rail section into the supply chain which may have led to additional stocking and inventory.
- Finally, the method of jointing any inclined rail to normal CEN60 would have been an unnecessary complication in track and would have introduced new products, thermit weld portions, fishplates and flash butt weld procedures. An inclined rail solution was not pursued for the normal running rails.
- Inclined baseplates: The traditional method of inclining rail in turnouts is to use a series of inclined cast iron or steel baseplates. This adds significantly to the inventory of the turnout as each rail foot requires a baseplate and fixings. This option was not pursued because of the cost for maintenance and of the supplies.
- Inclined concrete: Inclination of the rail seat on the concrete was considered and ruled out from the cost and complexity view point.
- Inclined rail pad system: It was considered that an inclined pad system incorporating the CEN60 standard 10mm resilient pad would be the simplest way of inclining the rail. The clip and insulator system could be kept standard and the number of components would be kept to a minimum. (Figures 4 & 5)



Fig 6: Pic caption here!!!!

RAIL CLIPS

A range of rail clips was considered.

For the turnouts, PANDROL e-PLUS clips were chosen for the design because of their simplicity, because they work parallel to the rail and they fit into the most restricted of areas between rails. Only one clip type is thus required throughout the turnout.

The use of PANDROL FASTCLIP was considered appropriate on the curved, checked track panels, to maintain continuity with the plain line and where no space restrictions are present. (See Figures 6 & 7)



Fig 7: Pic caption here!!!!

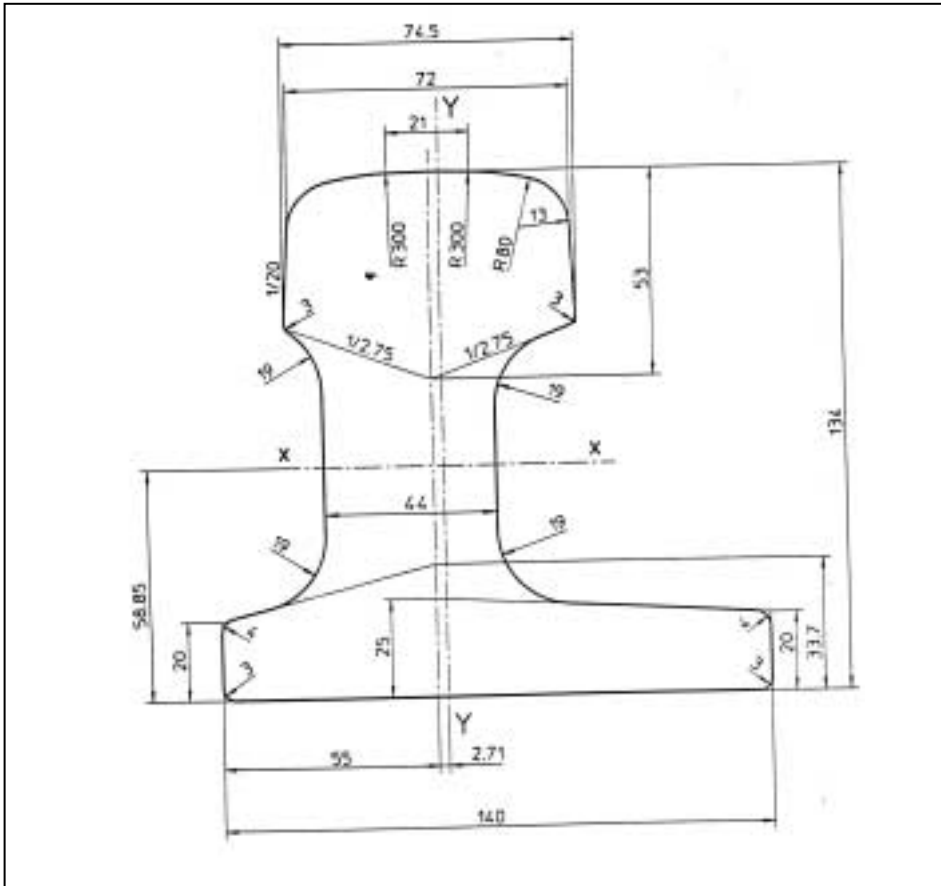

Fig 8: Pic caption here!!!!

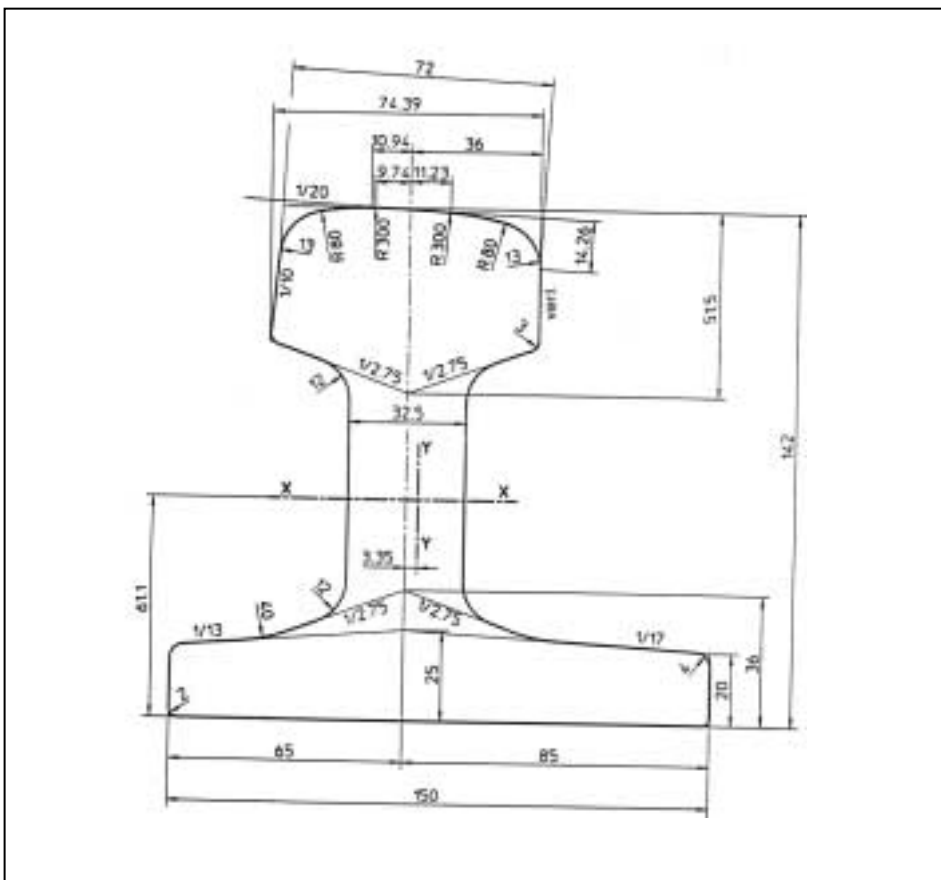

Fig 9: Pic caption here!!!!

Switch Tongue Rail

The choice of switch tongue rails was between CEN60E1A1 (UIC60B) – see Figure 8 or CEN60E1A4 (UIC60D) – see Figure 9. UIC60D was chosen because:

The rail section is rolled with an inclined 1 in 20 head which reduces machining and gives more reliable rail/wheel contact area; the UIC60D rail is used on the European High Speed lines and is the switch rail of choice for CTRL; the 60D rail has higher section modulus and moment values than 60B, Figures 10 and 11.

	60D	60B	±%
Moment XX (cm ⁴)	2025	1728	+17%
Moment YY (cm ⁴)	764	742	+3%
Section Modulus X (cm ³)	250	230	+8.5%
Section Modulus Y (cm ³)	94	90	+4%

These values will improve stability under 30 tonne axle loads.

Thanks to a higher basic moment of inertia (YY) than 60B, 60D when machined into a tongue rail gives lower switch opening forces and a more natural heel opening geometry. Further, the higher horizontal moment of inertia (XX) reduces stresses in the rail and improves lifetime (in particular for high axle load).

SWITCH SLIDEPLATES

Present thinking on the choice of switch slideplates is varied. The choice is between:

- Conventional lubricated cast baseplates
- Baseplate incorporating a 'dry' slide system, PTFE, UHDPE, phosphor bronze, manganese steel, etc.
- Roller systems
- Ball bearing systems
- Conventional cast baseplates with a low friction, lubrication free Ni/Cr fired on layer. (Figure 12)

The traditional lubricated baseplate is no

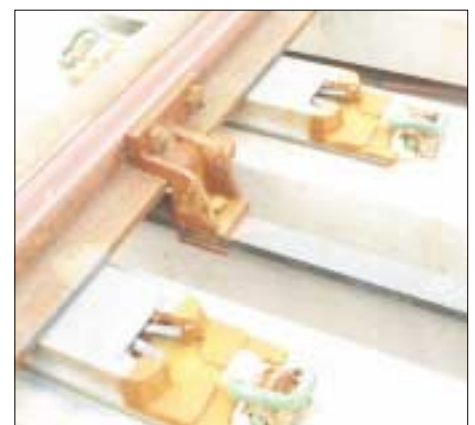

Fig 10: Pic caption here!!!!



Fig 11: Pic caption here!!!!



Fig 13: Pic caption here!!!!



Fig 14: Pic caption here!!!!



Fig 12: Pic caption here!!!!

longer favoured for maintenance reasons and the dry slide systems, PTFE, UHDPE, phosphor bronze, manganese steel, etc. have not had the performance of rollers and Ni/Cr.

For ease of simplicity, low maintenance and reliability, a slideplate with a Ni/Cr layer was chosen. These are used and proving themselves on Finnish State Railways and Norwegian State Railways. The Ni/Cr layer produces a very hard, wear resistant surface layer which is virtually maintenance free in service. In addition, its simplicity and lack of componentry ensures that very little can go wrong. Roller plates have not been discarded but they do require fine adjustment to ensure optimum switch operation.

SWITCH DRIVES AND INTEGRATION

The fitting of switch motor and integration tests are done in the factory prior to despatch. A purpose-made drive and detection panel has been constructed to suit a variety of switch motor drive systems.

CHECK AND CROSSING ASSEMBLY

It was decided that the check rail should be totally independent of the running rail. The check rail is mounted onto an independent cast SG iron bracket. There is no through check baseplate. This system allows the cast crossing to be full rail

depth and fastened directly to the bearer system without the need to make up the extra height imposed by a check baseplate. (Figures 13 & 14)

CROSSINGS

The cast crossings are cast manganese with welded legs reinforced for 30T axle load and with optimised design for load transfer. They sit on a 10mm resilient pad and are directly fixed to the bearers with 'Pandrol' e-PLUS clips.

Design of top running surface was developed to take into account the shape of an average worn wheel contour in order to provide at the beginning of operation the best matching wheel/crossing interface.

CONCLUSIONS

We believe our design philosophy has been fulfilled by these choices:

- The Pandrol clips are of one type and common throughout.
- The resilient pads are standard plain line pads mounted on an inclined (1 in 20) plastic wedge, these are located with standard clips.
- The screws for the check bracket use standard Railtrack head sizes. ■

Development of the Pandrol SFC Baseplate

Following the successful introduction of the 'Domed' shoulder housing on the PANDROL VIPA-SP noise and vibration system a number of requests were received by Pandrol to incorporate this feature in a standard baseplate.

The use of an accurate 'Shell Coring' system enabled the clip driving and locating features to be produced on the inside of the housing, thereby allowing the whole top surface of the plate to be formed clean from the sand, with virtually no post cast dressing required.

To take advantage of this revised manufacturing technique the PANDROL FASTCLIP post insulator system had to be redeveloped so as to avoid 'tunnels' through the cast head and the need to clean the flash line they bring with them.

The final design allows full advantage to be taken of the PANDROL FASTCLIP captive fastening system, whilst allowing up to 50mm of vertical adjustment to be achieved through the use of simple under-plate shims. This makes it an ideal product for non-ballasted trackforms where the speed and ease of installation and alignment both in the initial build and subsequent re-alignment is critical.

The plate can be delivered to site complete, with all the fastening components captive ready for the rail to be threaded, offering large benefits to the track construction groups both in terms of automated track laying and reduced overheads in transporting and handling the loose components.

The accompanying pictures illustrate the two forms of SFC baseplate, as modelled on Pandrol's 3D CAD system. ■

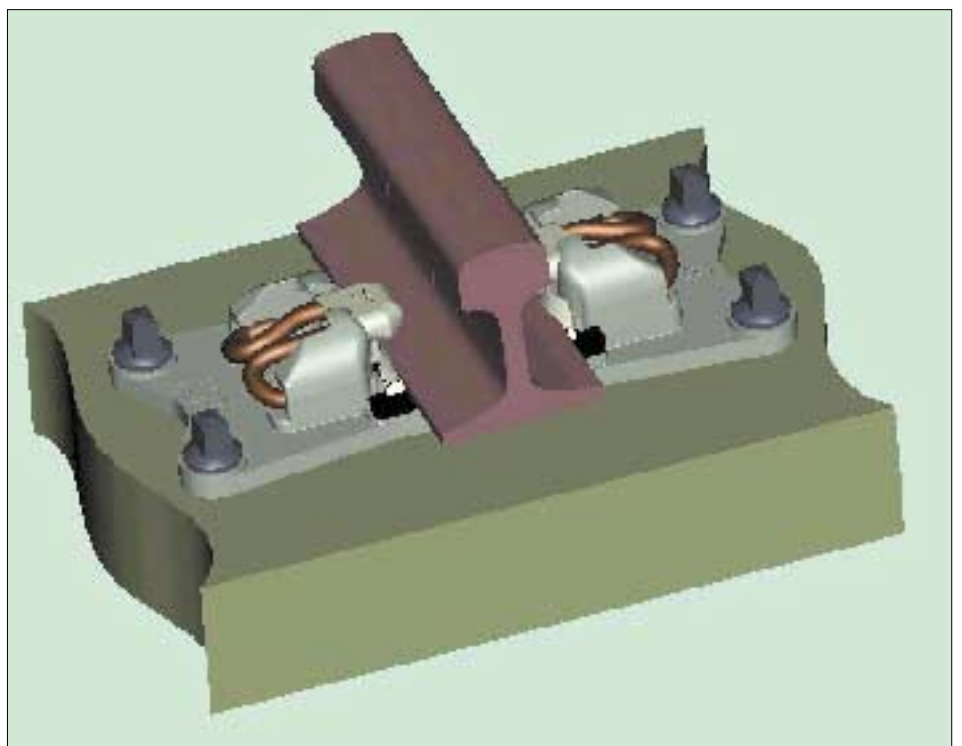
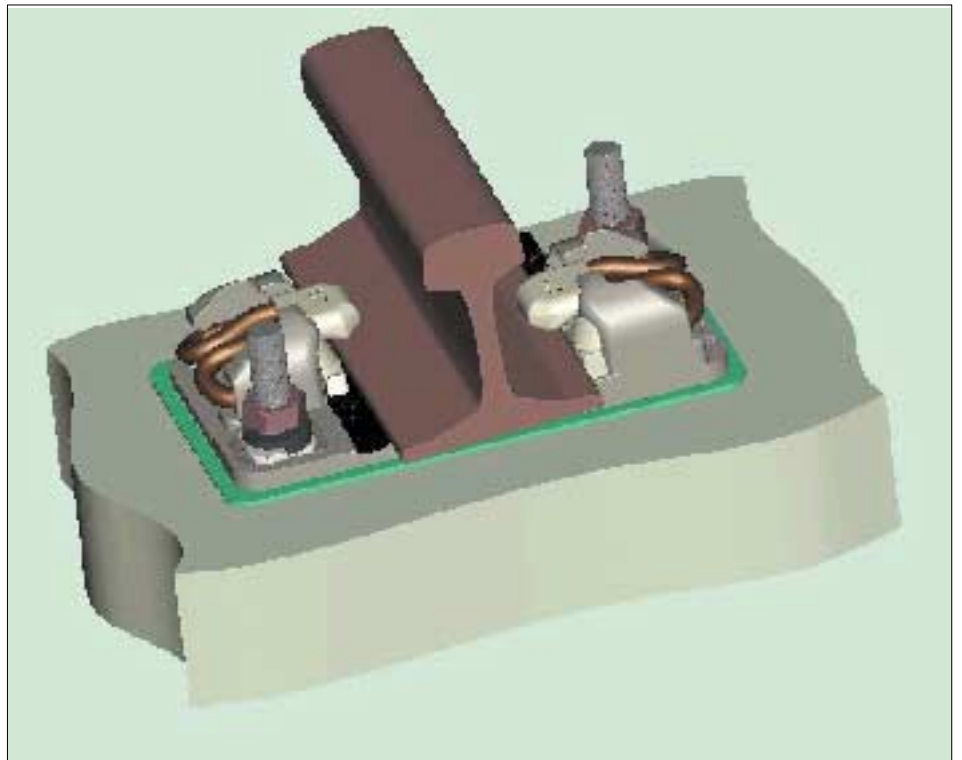

Pandrol Safelok III

by ?, address

The PANDROL SAFELOK III track fastening system has been specifically developed following requests made to Pandrol by current North American Railroad users of Safelok for a captive version of this system. The design brief was to develop a fully captive fastening assembly with the operating characteristics at least equal to those of the current SAFELOK system.

SAFELOK III has been designed for pre-assembly of the fastening components on the concrete sleeper at the sleeper plant. In the pre-

assembled position, the pad, side post insulator, clip and toe insulator are all captive. This allows secure transportation to site without component losses, and either manual or automated mechanical track installation. Track de-stressing, rail change and assembly maintenance can be conducted on the fastening system with the clip backed off the rail foot but held captive within the cast shoulder.

Following a detailed design and testing programme in the Pandrol Rail Fastenings Ltd Development Laboratory, assembly components

were procured for track trials in North America. During November 2000 and March 2001 trial installations of 120 sleepers took place on the UP Railroad at Horse Creek, Wyoming and on the BNSF Railroad at Crawford Hill, Nebraska. Pandrol has now been requested to install a further 1,000 sleepers on both the UP and BNSF Railroads. The installation took place during September 2001, with the BNSF to follow shortly.

All trial installation sites will be monitored through winter and spring 2001-2002. ■



Left: SAFELOK III installed in track at Crawford Hill Nebraska.

Below, top: SAFELOK III pre-installed position.
Below, bottom: SAFELOK III installed track position.

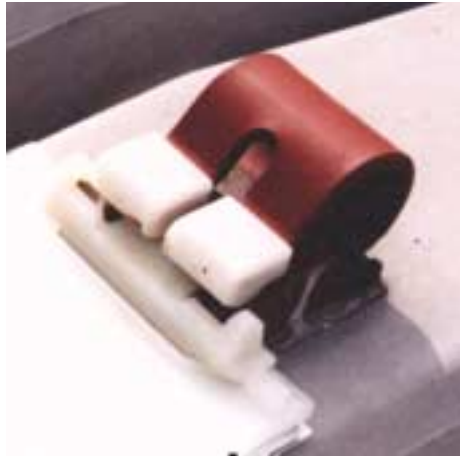

PANDROL VIPA Double FASTCLIP concrete slab track installation on the Changi Airport Line, Singapore. Trackwork by Balfour Beatty Gammon JV. Photo by John Latham of BBG-JV.

