

Operation & Maintenance Manual Alpha Grinder

Issue date:2019-07-10

Dokument ID:ENG_OMM_AlphaGrinder

Revision:P01

Original instructions



PANDROL

Pandrol AB, Hyggesvägen 4, 824 34 Hudiksvall, Sweden
Phone +46 650-16505, www.rosenqvistrail.com, info.rosenqvistrail@pandrol.com

Thank you for choosing Alpha Grinder!

You are now the owner of a quality product from Pandrol AB.

PREFACE

This manual aims to help you get to know your new Alpha Grinder, to use it in the best way and to maintain it properly for a long lifetime. It also presents important safety regulations and warnings.

The manual is intended for people who handle and operate Alpha Grinder. It is originally written in Swedish and then translated into the local language by Pandrol AB.

Pandrol AB reserves the right to change specifications, equipment, instructions and maintenance guidelines without prior notice.

The manual contains instructions about the following topics:

- Installation
- Operation
- Safety features and warnings
- Maintenance and troubleshooting

IMPORTANT!

This manual contains ordered actions, e.g.

1. Do this
2. ...and then this...
3. ...and finally this

These actions **must** be done in the numerical order presented.

REVISION NOTES

Date	Revision	Notes
2019-07-10	P01	New manual

TABLE OF CONTENTS

1	Safety Information	4
1.1	General	4
1.2	Safety Actions	4
1.2.1	Safety Equipment	5
1.3	General Warnings	6
1.4	Specific Warnings	6
1.4.1	Moving Parts	6
1.4.2	Live Current	6
1.4.3	Machine in Operation	7
1.4.4	Operator Leaves the Machine Unattended	7
1.5	Qualified Personnel	7
1.6	Warning Labels and Information Symbols	8
2	Machine Components	9
2.1	Main Unit	9
2.2	Technical Specifications	10
2.3	Conformance EN13977 Gauge	11
2.4	Controls	12
3	Installation and use	13
3.1	Installing grindstone	13
3.2	Installing on rail	13
3.3	Adjustments	13
3.4	Start the motor/machine	13
3.5	Operation Grinding	14
3.6	Remove grinder from track	14
4	Transport and Parking	15
4.1	Preparing for Transport or Storage	15
5	Maintenance	16
5.1	General	16
5.2	Maintenance Schedule	17
5.3	Grease Points	17
6	Mounting Torque for Screws & Nuts	18
7	Warranty and Service	19
7.1	Warranty	19
7.2	Service	19
7.3	Contact	19
8	Declaration of Conformity	19

1 SAFETY INFORMATION



1.1 General

The machine is designed to grind the railhead.

- Warnings and safety precautions described in this document shall only be considered as a minimum. National conditions, standards and regulations override conditions, standards and regulations described in this document.
- Work with the machine is only to be carried out by qualified personnel, well-informed and educated in general railway workmanship and specifically in the conditions, standards and regulations on specific rail track.
- The machine may only be used for its specified purpose.
- Any adjustments or service on the machine is only allowed to be done by qualified personnel that have read and understood this manual and have had training and information from Pandrol AB.

1.2 Safety Actions

- Read and understand all safety regulations and warnings before installation, operating or performing maintenance on this machine.
- Locate stop buttons, emergency stop buttons and keys before installation, operating or performing grinding with this machine. The emergency stop button is not allowed to be used to stop the machine normally.
- The machine is never to be used as a transport vehicle for personnel or equipment.
- Be sure that unqualified persons are not in the operating area during installation, use or maintenance.
- Safety regulations regarding personnel in operating area for the Alpha Grinder are valid for this machine.
- Use standards and regulations, accident prevention regulations and regulations concerning special ambient conditions (e.g. areas potentially endangered by explosive materials, heavy pollution or corrosive influences).
- It is of great importance that all service, component replacements or other operations in the electronic or motor are accomplished by qualified personnel only.
- The use of solvents as cleaning agents and the use of lubricants can involve health and/or safety hazards. The manufacturers of the solvents and lubricants should be contacted for safety data. The recommended precautions and procedures of the manufacturers should be followed.
- The use of an air jet, which must be less than 8 bar, to blow parts clean or to blow them dry after being cleaned with a solvent will cause particles of dirt and/or droplets of the cleaning solvent to be airborne. These conditions may cause skin and/or eye irritation.
- When using an air jet do not direct it toward another person. Improper use of air jet could result in bodily injury.
- The machine is not allowed to be used on a track that is open for traffic.
- Caution shall be exercised when the operator leaves the Alpha Grinder especially when adjacent track is trafficked and can endanger the safety.
- Personal eye protection must be worn when undertaking work.
- Personal ear protection must be worn when undertaking work.

- All personnel except for the operator are to be kept at least 3 m from machine when working.
- Operators and service personnel should wear appropriate protective equipment, such as gloves, goggles and overalls.
- Alpha Grinder is only to be used by trained personnel, thoroughly familiar with and trained in general railway workmanship.
- The equipment should be operated according to the conditions and standard regulations applying to the track they are working on.
-

1.2.1 Safety Equipment

The machine is to be equipped with safety equipment according to national requirements.

1.3 General Warnings

- Incorrect installation, maintenance and/or operation of this equipment may be dangerous and may result in severe personal injuries.

1.4 Specific Warnings

1.4.1 Moving Parts

When operated, some parts of the Alpha Grinder are moving. Moving parts can cause personal injury. To avoid accidents, follow the guidelines below:

- Keep hands etc. away from moving parts when operating the machine
- Make sure no unauthorized personnel are in the working area when working the machine



WARNING! Moving parts - risk of crushing

1.4.2 Live Current

Contact with electric parts can damage the equipment if live current is present. To avoid accidents, follow the guidelines below:

- If electricity needs to be connected for testing purposes: keep hands, tools etc. away from all electrical parts.

In any other case:

1. Shut off the vehicle engine



WARNING! Live current - risk for damage on equipment and/or people

1.4.3 Machine in Operation

Special precautions must be taken to ensure that operation of the machine will not result in severe injury and/or damage to the equipment or personell.

To avoid accidents, make sure no one is in the vicinity of the machine before operation is started.

1.4.4 Operator Leaves the Machine Unattended

When the operator leaves the machine unattended, the machine must always be parked horizontally on the ground.

1.5 Qualified Personnel

The Alpha Grinder is only to be used by trained personnel, thoroughly familiar with and trained in general railway workmanship. The equipment should be operated according to the conditions and standard regulations applying to the track they are working on.

The equipment must be serviced, maintained, or in any way modified only by trained personnel, who are familiar with the Operation & Maintenance Manual and have received training and information from Pandrol AB.

In order to avoid personal injury and/or material damage, everyone involved with assembling, starting-up or overhaul must possess relevant knowledge of the following

- The automation technology sector
- Dealing with dangerous voltages
- Using standards and regulations, accident prevention regulations and regulations concerning special ambient conditions (e.g. areas potentially endangered by explosive materials, heavy pollution or corrosive influences)..



WARNING!

- Touching parts that are subject to high voltage may cause grave damage to health
- All maintenance and service on the electric system is to be carried out by qualified personnel

1.6 Warning Labels and Information Symbols

Below are examples of warning labels and information symbols on the machine. If any of these labels become damaged or lost, they are to be replaced with new original warning labels that are available from Pandrol AB.



Read manual before use
(item no. 710016)



Wear safety goggles
(item no. 710048)



Wear hearing protection
(item no. 710052)



WARNING: Risk of crushing
(item no. 710019)



WARNING: Electrical danger
(item no. 710018)



Do not ride or stand on
machine
(item no. 710021)



Emergency stop
(item no. 710014)

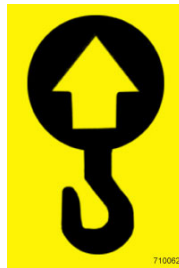

Lifting point
(item no. 710062)

2 MACHINE COMPONENTS

2.1 Main Unit

The Main Unit is the heart of Alpha Grinder. It contains the engine and components. The handle bar with the operator controls is also mounted on the Main Unit.

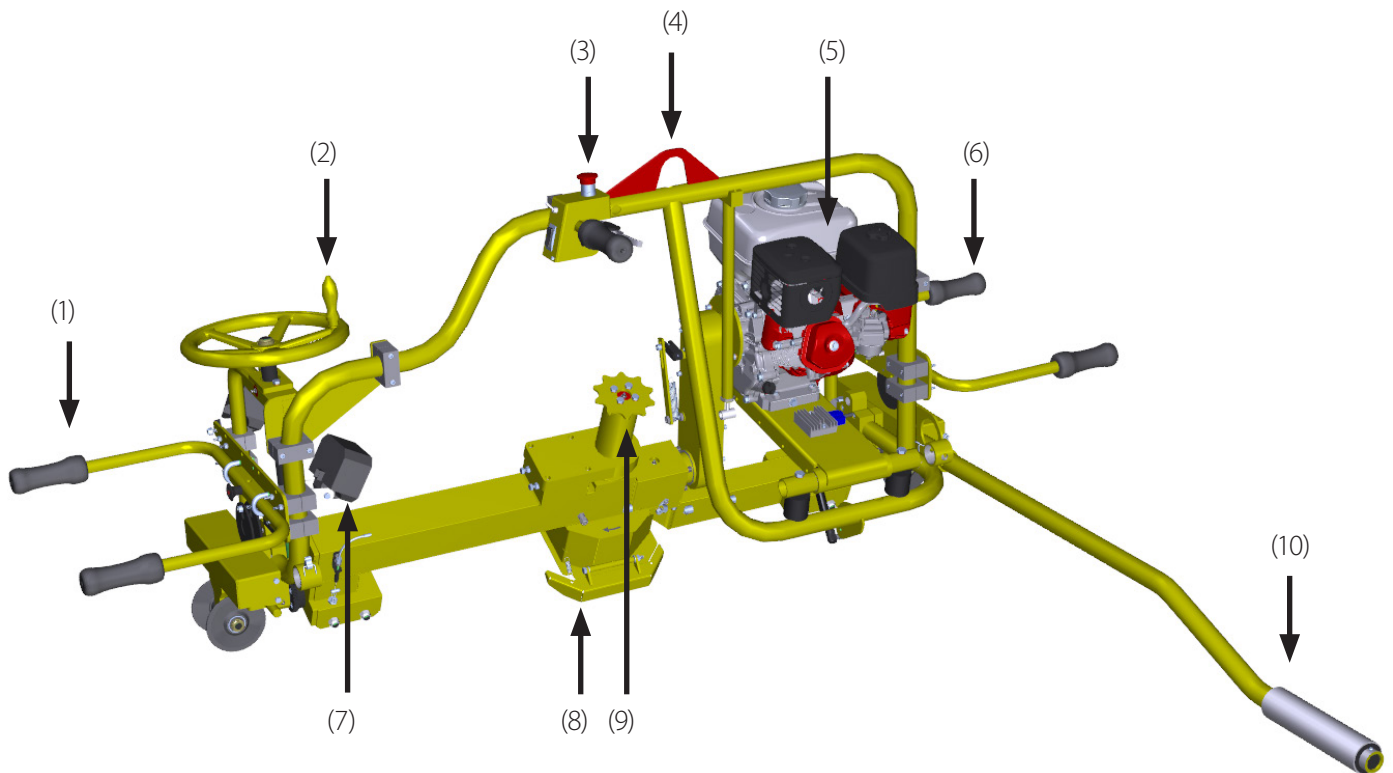
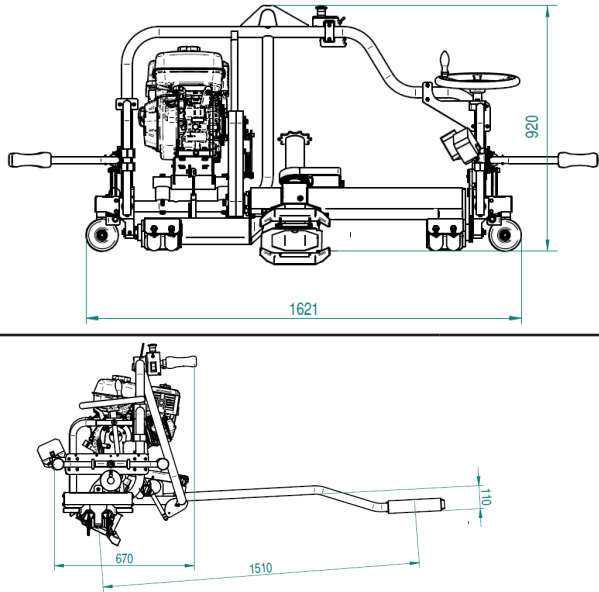

Fig. 1

Item	Description	Item	Description
(1)	Lifting handles - support legs	(6)	Lifting handles - support legs
(2)	Height adjustment - grind stone	(7)	Working lights
(3)	Controls	(8)	Grind stone
(4)	Lifting eye	(9)	Angle adjustment - grind stone
(5)	Motor	(10)	Support roller unit

2.2 Technical Specifications

		Alpha Grinder	
Measurements	Measures		
	Weight	105 kg	
Grindstone	Diameter, outside	150 mm	
	Diameter, inside		
	Height		
	Running speed	4000 rpm	
Min/Max angle of operation			
Engine	Manufacturer	Honda	
	Model	GX 270	
	Type	Air cooled 4-stroke OHV petrol engine. 25 inclined cylinder, horizontal shaft. Cast iron sleeve	
	Power	5,1 kW 3600 Rpm	
	Fuel	Automotive gasoline (unleaded)	
	Fuel tank capacity	5,3 litre	
Electronics	Voltage	12 volt DC	
	Ground	Negative	
Noise data	Noise level, idle running	measured on all four sides, 1 meter	93,2 dB
	Noise level, full speed	measured on all four sides, 1 meter	95,8 dB
Vibration data	Grinding	Front right handle	8,94 m/s ²
	Grinding	Rear handle (adjustment wheel)	4,18 m/s ²

2.3 Conformance EN13977 Gauge

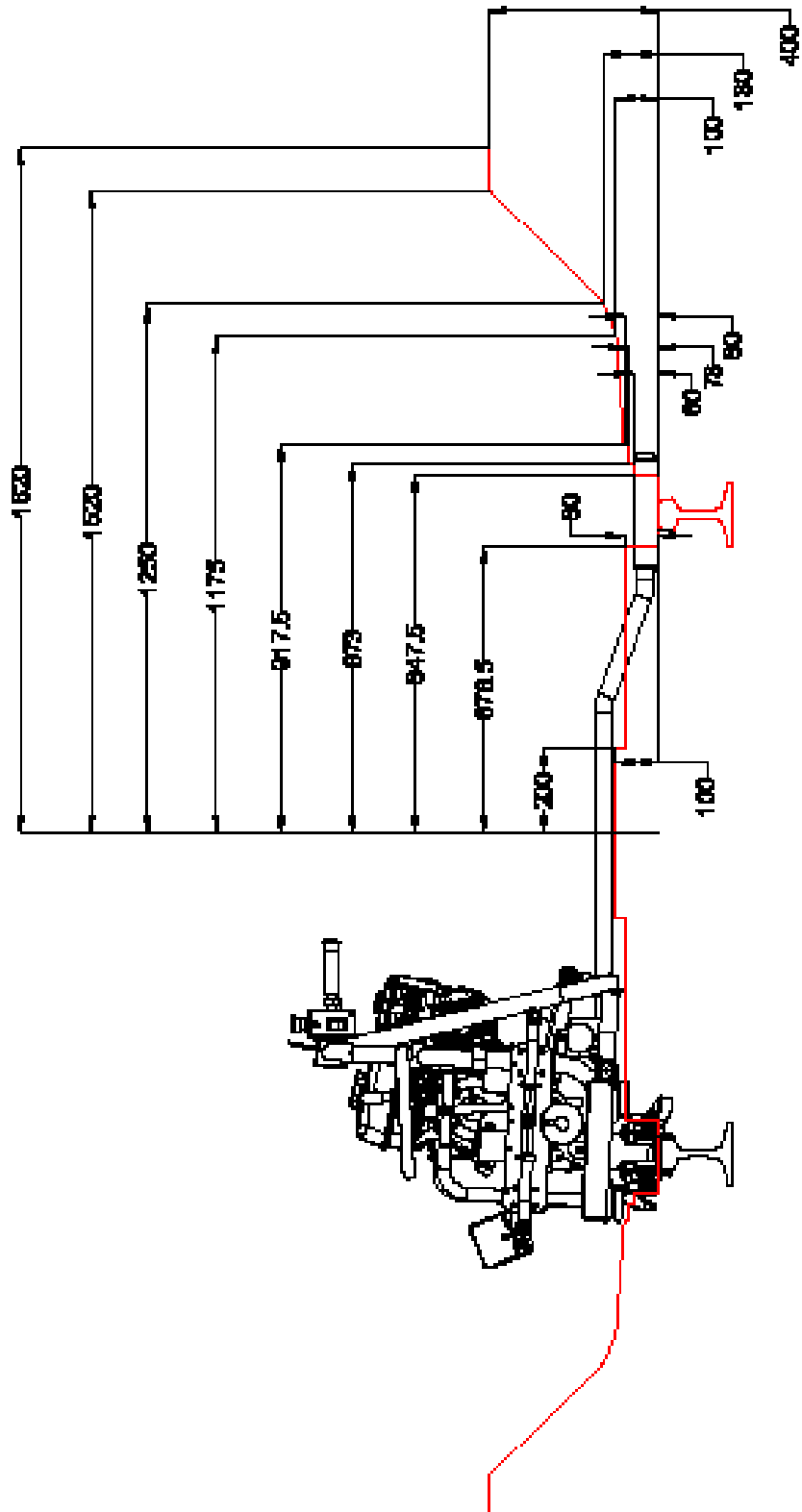

2.4 Controls

The Alpha Grinder is operated by the operator, Fig.2, Fig 3.

	<p>WARNING! Do not operate the machine before performing the setup procedure.</p>
---	--

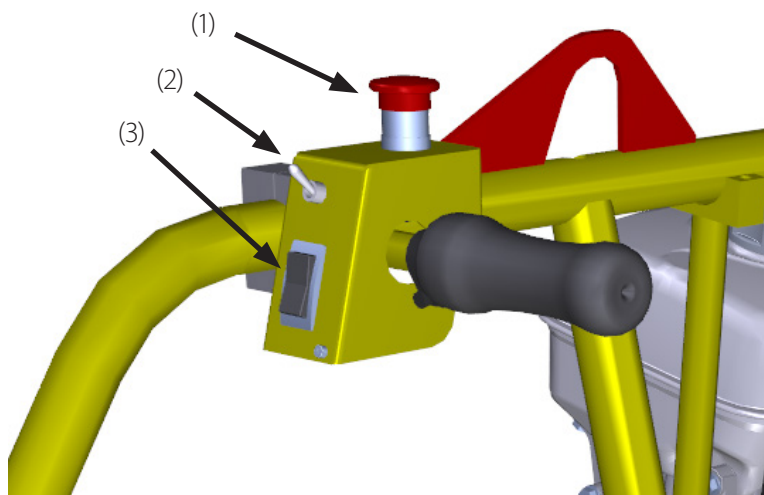

Fig. 2

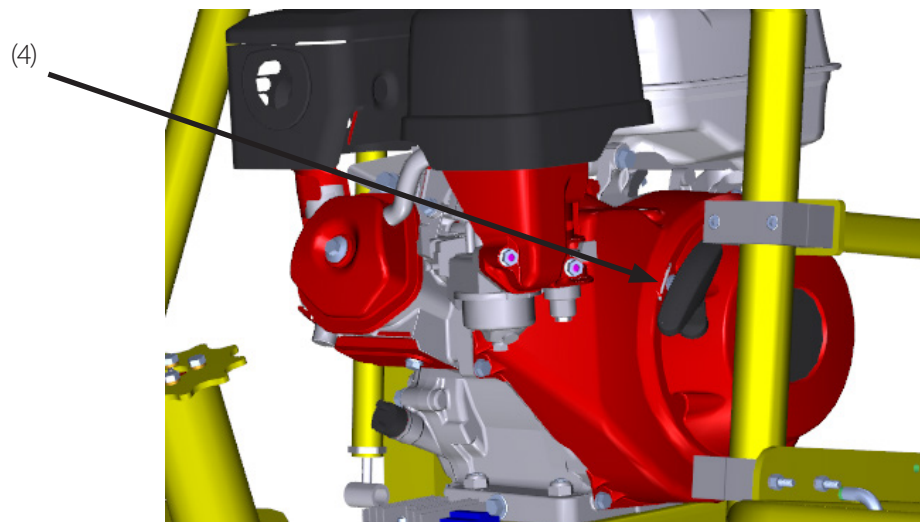

Fig. 3

Item	Description	Item	Description
(1)	Emergency stop button	3	Grindstone angle
(2)	Light switch	4	Start cord

3 INSTALLATION AND USE

3.1 Installing grindstone

The engine has to be **switched off** when mounting/dismounting the grindstone or when the machine is resting on the ground.

Dismounting grindstone

1. Place the grinding machine stable and suitable for replacing the grindstone.
2. Remove the cover around the grindstone, 3 screws M8 M6S
3. Lock axle with key size 24
4. Unscrew the adapter for the grindstone with key size 24 from the axle.
5. Release the adapter from the grindstone and replace/fit the new.

Mounting the grindstone

Follow the description above in reverse order.

3.2 Installing on rail

The engine has to be switched off when mounting/dismounting the machine or when the machine is resting on the ground.

Inspect the Alpha grinder to make sure there are no damages and that it is completely free from defects.

3.3 Adjustments

Check rail width, allowed play 5-15 mm.

Check the play between rail and grindstone, clearance has to be at least 1 mm. Adjust with wheel/knob.

3.4 Start the motor/machine

Make sure all safety information have been read before starting the machine.

Ensure all pre checks have been conducted. The machine must only be started on the track.

1. Start with the machine in the flat position and with the grindstone in the horizontal position.
2. Check the clearance between the grindstone and the rail. The grindstone must be clear from the weld.
3. Check that the protection cover is in place and is folded down.
4. Check that the emergency stop is extended.
5. Start the engine by holding the grip and pulling the start cord until motor starts, allow the cord to retract.

3.5 Operation Grinding

Make sure all safety information have been read before using the machine.

1. Set the grinder to max.
2. Gently lower the grindstone over the grinding point on the rail. until it fires fire from the grinding point.
3. Move the grinder back and forth over the grinding point/weld, lowering the wheel until the weld is 1 mm above the rail head.
4. Repeat the procedure until it is flat.
5. Rotate the machine sideways to grind the side of the rail until the weld is 1 mm above the rail head. The angle adjustment makes it possible to work on both sides of the rail without turning the machine around.

3.6 Remove grinder from track

Lift the machine off the rail and park it with the handles folded down. Release arm and place on machine in transport position.

DO NOT lift the Alpha Grinder manually.

Make shure the machine is lifted in lifting eye. Use a lifting device suitable for the purpose.

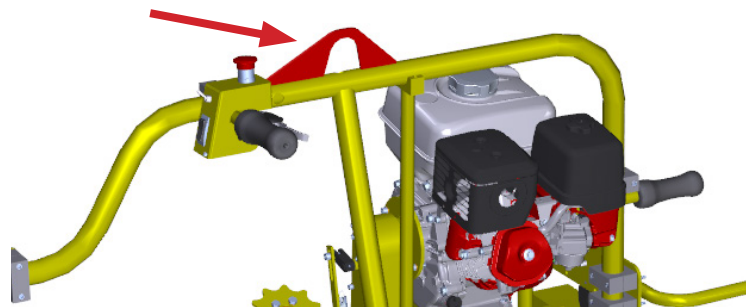

Fig. 4

4 TRANSPORT AND PARKING

4.1 Preparing for Transport or Storage

Place the Alpha Grinder on a flat surface. It must stand straight up. Use straps to fasten and secure.

DO NOT lift the Alpha Grinder manually.

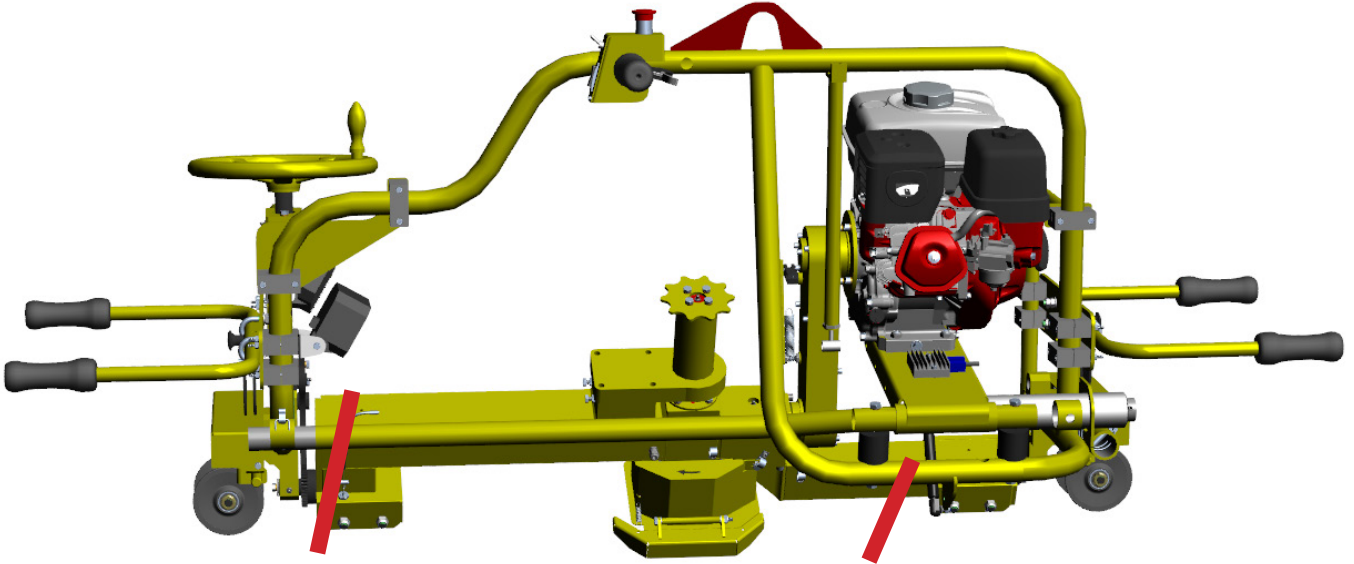

Fig. 5

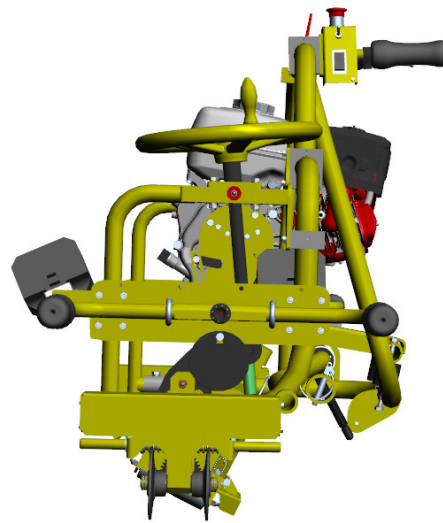

Fig. 6



WARNING!

- The Alpha Grinder must only be operated by trained personnel and with experienced workmanship.
- All safety precautions and other requirements is the responsibility of the equipment operator.
- Operation or preparation for use can be dangerous and may cause serious personal injuries if not correctly performed. All safety and necessary precautions shall be taken by the operator of the machine. The machine operator is also responsible that nobody interferes with the Alpha Grinder whilst in use and powered.

5 MAINTENANCE

5.1 General

MAINTENANCE AND OVERHAUL IS TO BE CARRIED OUT BY QUALIFIED PERSONNEL ONLY

The Alpha Grinder is designed for the absolute minimum of maintenance. All its components have been chosen for a long working-life and high quality.

The Alpha Grinder requires:

- A minor maintenance before and after every working shift
- A lubrication every 40 hours or once a week
- A more comprehensive overhaul after 500 hours or once a year

Warranty is based on parts and spares delivered by Pandrol AB.



WARNING!

- All adjustments work, overhaul and service must take place with the engine turned off, cooled down and with grinding stone disengaged. Failure to do so could lead to fatal injury.
- It is of great importance that qualified personnel accomplish all service and overhaul

5.2 Maintenance Schedule

Item	Servicing Action	Frequency			
		Each time used	Once a week or every 40 hours	Once every 6 months or 250 hours	Once a year or every 500 hours
Entire unit	Check for oil leakage	X			
Screws and nuts	Check/tighten if needed	X			
Grind stone	Check/replace if damaged	X			
Grease points on grinder	Lubricate with grease SKF LEGP 2 or equivalent		X		
Roller surface on slide bar	Clean and lubricate with oil spray*		X		
Bolts	Lubricate with oil spray*		X		
Engine	See Honda manual	X	X	X	X
Warning labels	Replace worn and replace missing labels	X			

*) CRC5-56 or similar

**) Let the machine rest at least on hour before checking level

***) Recommended hydraulic oil:

At temperatures below 25 °C is oil of viscosity grade 46 recommended

At temperatures above 25 °C is oil of viscosity grade 68 recommended

It is **very important** that the service intervals are thoroughly followed to guarantee the safety and the performance of the machine

5.3 Grease Points

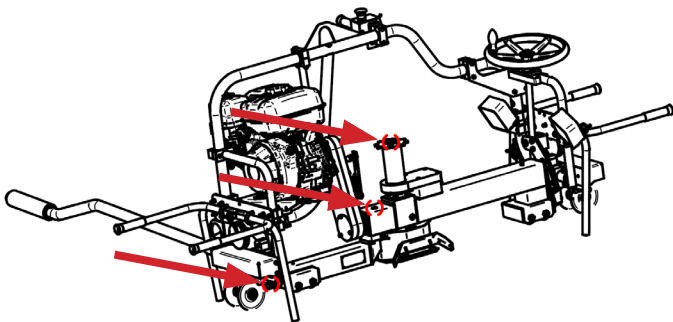

Fig. 7

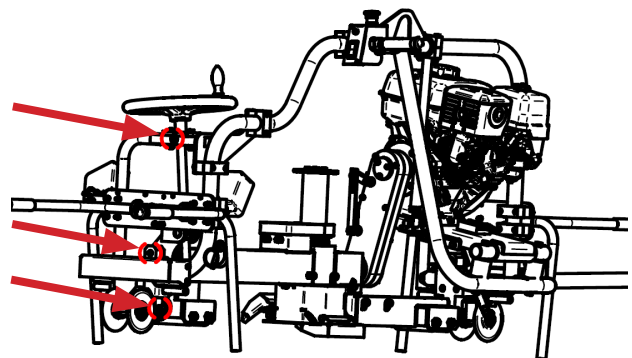

Fig. 8

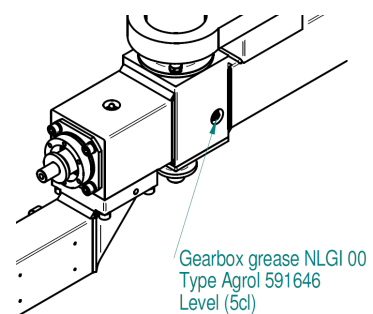

Fig. 9

6 MOUNTING TORQUE FOR SCREWS & NUTS

The preload force must be maintained at a level where the tensile stress and the intensity of the torsional stress do not exceed the screws yield stress for the specific material. Its main function is to clamp together the assembled parts and produce friction force between the assembled parts.

At Pandrol AB we mainly use steel screws and nuts. The table below shows the nominal tightening torque in Nm for the screws and nuts that are used

These torques do not apply to wheel bearings!

Table 1

Thread diameter [mm]	Tightening Torque (per bolt grade) [Nm]		
	Grade 8.8	Grade 10.9	Grade 12.9
5	5,7	8,1	9,7
6	9,8	14	17
8	24	33	40
10	47	65	79
12	81	114	136
14	128	181	217
16	197	277	333
18	275	386	463
20	385	541	649
22	518	728	874
24	665	935	1120
27	961	1350	1620
30	1310	1840	2210
33	1770	2480	2980
36	2280	3210	3850



IMPORTANT! Check that all bolts and nuts are tightened at least every 8 hours until 80 hours have been reached. If necessary, use spanner to tighten.

7 WARRANTY AND SERVICE

7.1 Warranty

All products from Pandrol AB are subject to a 12 month warranty.

The warranty does not apply if the product defect or flaw in question exists because of or is a result of improper use, tampering, or unauthorized modification, or if the product has been exposed to fire, electrical storms or excessive voltage.

7.2 Service

Service is offered after the expiration of the warranty as well. Please contact Pandrol AB.

7.3 Contact

Address

Pandrol AB
Hyggesvägen 4
824 34 Hudiksvall
SWEDEN

Telephone

Tel.: +46 (0) 650 165 05

Internet and E-mail

www.rosenqvisttrail.com
info.rosenqvisttrail@pandrol.com

8 DECLARATION OF CONFORMITY

Insert a copy of the Declaration of Conformity in this section.

Page intentionally left blank



PANDROL

Partners in excellence

Pandrol AB, Hyggesvägen 4, 824 34 Hudiksvall, Sweden
Phone +46 650-16505
www.rosenqvistrail.com
info.rosenqvistrail@pandrol.com