

ITEM	DESIGNATION	QTY
1	NABLA® CLIP	2
2	MVG4 BASEPLATE	1
3	NABLA INSULATOR	2
4	MVG4 PAD	1
5	SCREW	2
6	WASHER	2
7	BUSH CLAM	2
8	ANCHORAGE INSERT	2
9	T-BOLT	2
10	WASHER	2
11	NUT	2
12	CONFORMING SHIM	1
13	SHIM	1

Requirement for 1 rail seat

ISOMETRIC VIEW

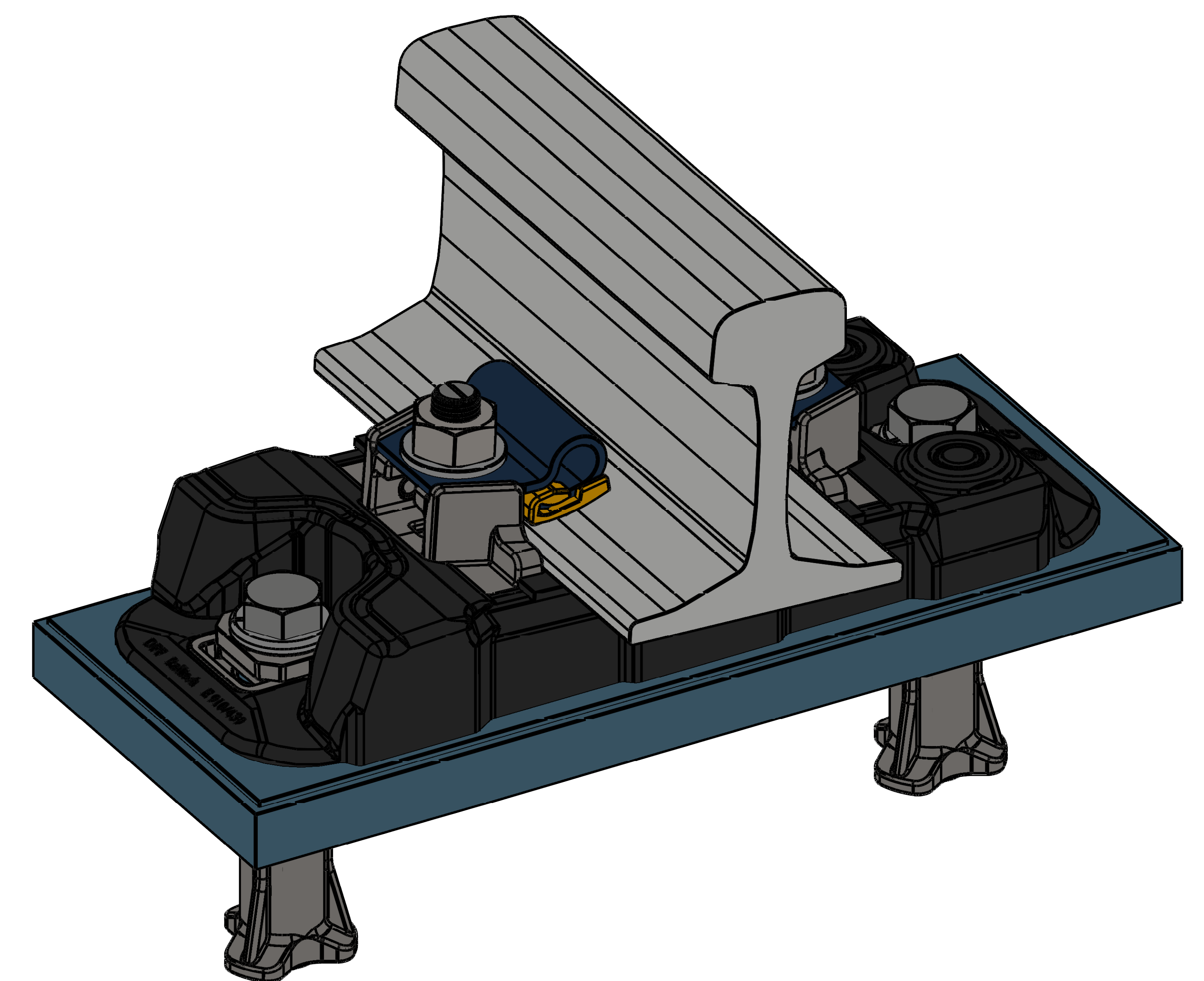

PANDROL

E-MAIL: INFO@PANDROL.COM
WWW.PANDROL.COM

TITLE

ADH MVG4 ASSEMBLY

DRAWING No.

ADH

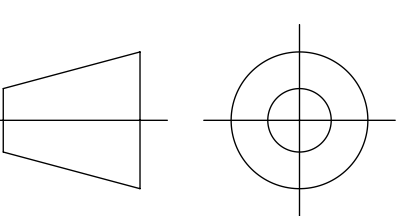

© PANDROL 2020

ISSUE

1

SIZE

A0