

# Fastclip FE RR

Fastening systems

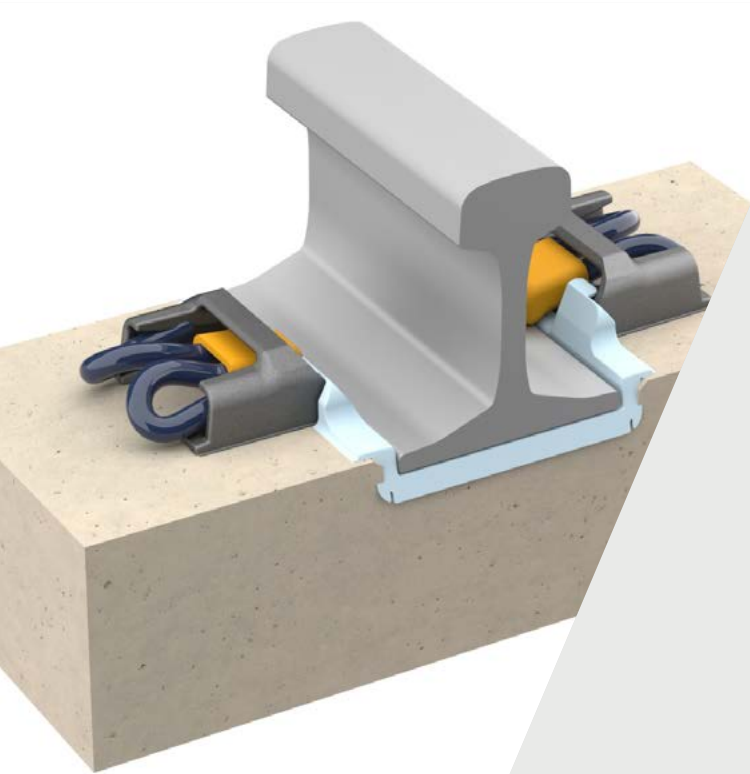

Pandrol's Fastclip FE RR rail fastening system is designed specifically for extreme heavy haul applications. It is suitable for an axle load of up to 40 tonnes and curve radius down to 150 metres.

Fastclip FE RR sleepers are supplied to the track pre-assembled, with all components held captive and the clips set in parked position. Once the sleepers have been placed and the rail threaded, the clips are simply pushed into the installed position. A recessed rail seat and two-part combined rail pad and insulator help to ensure that the system provides long service life.

## → TECHNICAL FEATURES

### Clip type

The FE RR system uses Pandrol Fastclip FE1505 clips for threadless, self-tensioned fastening.

### Switch on-switch off function

The clips are supplied in the parked position, held securely but not intruding into the rail seat. They can then be switched quickly and easily into the installed position.

### Captive fastenings

Sleepers are supplied to the track construction site as pre-assembled units, with captive fastenings and no loose components.

### Mechanisation

Predominantly designed for mechanised track operation, Fastclip FE RR is compatible with a wide range of equipment. However, it is also suitable for manual installation where required.

### Performance limits

The standard maximum axle load for the FE RR system is 400kN. The minimum curve radius is 150m.

### Compliance

The standard Fastclip FE RR system is compliant with the requirements of EN13481-2:2012 and with AREMA Chapter 30 part 4.

## → ADVANTAGES /

- The Fastclip FE RR system has been specifically designed to provide exceptional performance in extreme heavy haul applications.
- Delivered pre-assembled on the sleeper, the FE RR system's captive fastenings and compatibility with mechanised equipment ensure efficient track construction and maintenance.
- The unique Pandrol 'switch on-switch off' function enables fast and efficient track installation and reduced maintenance costs.
- The threadless technology is ideally suited to extreme heavy haul operations, delivering high-quality track and low maintenance requirements.
- The system's recessed rail seat and two-part combined rail pad and insulator ensure that components have a significantly longer life than other fastening systems.

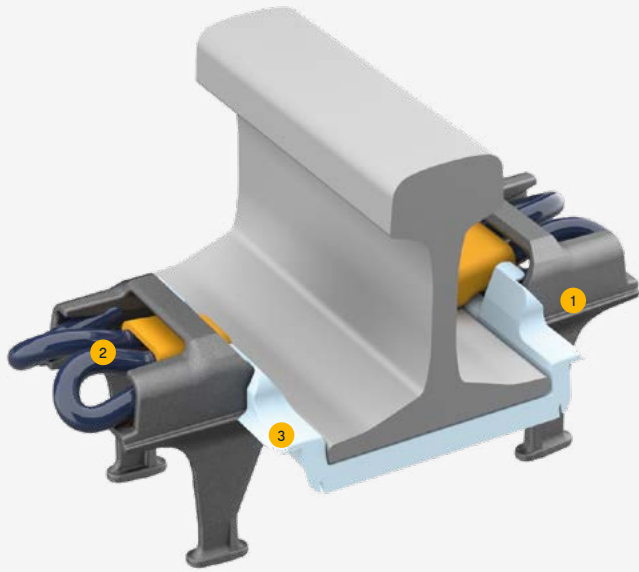

## → COMPONENTS /

1. FE RR Shoulder
2. FE HH Clip assembly
3. FE RR Rail pad / Insulator assembly

→ LEARN MORE



[www.pandrol.com](http://www.pandrol.com)

V.1-0623