

FCA Common Interface

Fastening systems

Common Interface Range

A proven futureproofing fastening system that provides the ability to tune track performance quickly and affordably.

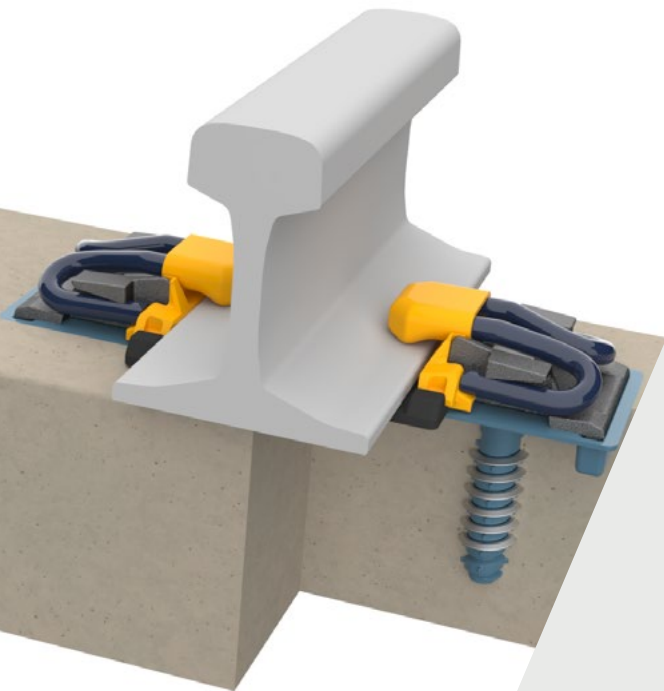

The Fastclip FCA rail fastening is designed for use on slab tracks where vertical adjustment is required and does so without the need for a baseplate. The product can be pre-assembled and delivered to site captive on the pre-cast element, providing substantial cost savings.

Pandrol have created rail infrastructure in more than 100 countries, with the ability to deliver the highest quality industry standard to the most special of applications.

→ TECHNICAL FEATURES

Common interface

The FCA shares a common interface that can accommodate FCA, DFC and Vanguard fastening systems, allowing for different levels of stiffness (resilience) without changing the substrate.

Optimised for ballastless tracks

The Fastclip FCA system is suitable for use with all forms of pre-cast elements, including mono block, independent blocks and slab panel. Pre-cast elements may be cast-in or resiliently mounted.

Custom stiffnesses

Track stiffness to suit typical CEN track categories A, B, C and D applications. Custom stiffnesses can be provided.

Fully pre-assembled

The Fastclip FCA system can be delivered to site fully pre-assembled (captive) on pre-cast concrete elements.

Highly adjustable

Total track gauge adjustment of 20 mm (10 mm per rail seat) can be facilitated by custom side-post insulators. Vertical adjustment of + 30 mm is facilitated by custom components and shims.

Highly evolved

Fastclip FCA is an adjustable evolution of the globally trusted Pandrol Fastclip product. Component materials are based on long established Pandrol specifications. Low clamping force, joint-bar and rail-free variants are available to meet special track needs.

High electrical insulation

The Fastclip FCA assembly offers high levels of electrical insulation, reducing the risk of track circuit failure.

→ ADVANTAGES

- The high degree of flexibility offered by being able to change the fastenings on the common interface allows for greater futureproofing of non-ballasted track than in the past. Where noise and vibration concerns demand changes to stiffness, instead of having to modify or rebuild the whole track, the fastening system alone can be changed. This saves time, results in minimal disruption to track access and reduces cost.
- The FCA has been designed for ease of installation and maintenance with minimal tools, cutting maintenance inventory and time using a wide variety of manual / automated maintenance and stressing equipment.
- The FCA has been designed for slab track systems with a track stiffness of > 40 MN/m (depending on track category).
- The system provides full electrical insulation and corrosion protection.
- Available in low toe load and zero longitudinal restraint (ZLR) configurations, the FCA is suitable for bridge and viaduct applications. It can be used for stiffness transitions using variable stiffness rail and baseplate pads.
- The commonality of the FCA simplifies tooling, inventory and training for concrete plants.

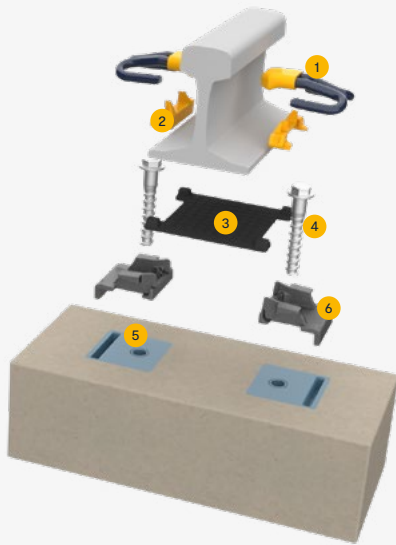

COMPONENTS

1. Clip and Toe insulator (ZLR and low toe load option available)
2. Side-post insulators
3. Rail pad
4. Anchor screws with plastic inserts
5. Plastic construction plates
6. Cast iron shoulders

→ SPECIFICATIONS

Assembly performance data

Recommended categories	A, B, C, D
Type of track	Slab
Rail inclination	1/20 or 1/40 (typical)
System type	Fastclip
Static stiffness	> 40 MN/m
Dynamic stiffness	> 50 MN/m
Lateral adjustment	± 6 mm
Vertical adjustment	Up to + 30 mm
Gauge adjustment	± 12 mm
Electrical insulation	> 10 kΩ

Performance values can be varied, depending on product configuration. For any other configuration, please contact us.

Standard compliance

- EN 13146 / Arema Test Methods

→ LEARN MORE



www.pandrol.com

V1.1-0426